

1 Angles

Lab 1.1: Angles Around a Point

Prerequisites: There are no prerequisites other than knowing that there are 360° around a point. I often use this lab on the first day of school.

Timing: To get the most out of this activity, you should plan to spend at least two periods on it. Students need time to understand what is expected, to search for many solutions, and to discuss their work as they go.

There are many ways to solve the problem with, say, two colors and three blocks. It is enough to find one of the ways to circle that number.

The essential purpose of this lesson is to develop a rough quantitative sense of angle measurement without dwelling on the actual numerical values of the measurements. Make sure that all students are able to think (and therefore talk) about the activity at some level. However, if some students are ready for, and use, actual angle measurements, do not discourage that! Expect all students to get into this more formally in the next lab. When students start thinking that they have found every possible answer, you may reveal that there are 42 solutions altogether. This helps clarify things if there are actually many unfound solutions, but it may sabotage the quality of the discussion, since it takes away the opportunity to discuss Question E, which itself is an incentive to think about Questions F–I. Note that the impossible cases are of two types: logical and geometric. For example, solutions with four colors and three blocks are logically impossible. The cases that are impossible by virtue of the size of angles are more interesting from the point of view of the purpose of the lab.

Answers

Colors:	How many blocks you used:
all blue	③ ④ ⑤ ⑥
all green	③ ④ ⑤ ⑥
all orange	③ ④ ⑤ ⑥
all red	③ ④ ⑤ ⑥
all tan	③ ④ ⑤ ⑥ ⑧ ⑫
all yellow	③ ④ ⑤ ⑥
two colors	③ ④ ⑤ ⑥ ⑦ ⑧ ⑨ ⑩ ⑪ ⑫
three colors	③ ④ ⑤ ⑥ ⑦ ⑧ ⑨ ⑩ ⑪ ⑫
four colors	③ ④ ⑤ ⑥ ⑦ ⑧ ⑨ ⑩ ⑪ ⑫
five colors	③ ④ ⑤ ⑥ ⑦ ⑧ ⑨ ⑩ ⑪ ⑫
six colors	③ ④ ⑤ ⑥ ⑦ ⑧ ⑨ ⑩ ⑪ ⑫

There are 40 solutions altogether.

Discussion Answers

- A. Green, orange, and yellow offer unique solutions because, for each one, all angles are the same size.
- B. Using the smaller angle, it takes 12 blocks. Each time you want to add a large angle, you have to remove five small ones, so altogether you have removed four blocks.
- C. The blue and red blocks are interchangeable because they have the same angles as each other.
- D. Answers will vary.
- E. Answers will vary.
- F, G, H. See chart. In order to use many blocks, the angles have to be small. But the more colors that are required, the more you are forced to use the blocks that do not have small angles.
- I. Even if you use the smallest angles for each block, their sum is still greater than 360° .

Lab 1.2: Angle Measurement

Prerequisites: The previous lab (Angles Around a Point) is recommended.

This activity should help students consolidate their grasp of the concept of angle to the point that they are ready to learn how to use a protractor if they do not yet know how.

If they have no idea about how to solve Problem 2, suggest they arrange blocks around a central point, as in Lab 1.1. Discourage the use of a protractor for this problem, as the point here is to use logic and develop understanding.

You may have the students cut out random paper triangles and find the approximate measures of their angles with the protractor they made in Problem 3.

To use the template protractor for drawing angles in Problem 5, suggest the following procedure:

- Draw one side of the angle; mark the vertex.
- Place the center of the protractor on the vertex and line up the desired measurement with the existing side.
- Draw the other side along the edge of the template.

Answers

- 72°
 - 120°
 - Answers will vary.
 - 30°
 - 90°
- Red and blue: 60° and 120° ; yellow: 120° ; orange: 90° ; tan: 30° and 150° ; green: 60°
- See student work.
- All angle sums should be about 180° .
- See student work.

Lab 1.3: Clock Angles

Prerequisites: The previous lab (Angle Measurement) is recommended.

This exploration is wide open and can serve to assess student understanding. The better that students understand angles (and proportions), the more difficult they can make this challenge for themselves.

The discussion questions can help prepare students for the activity.

Answers

Student reports will vary. The angle at 5 o'clock is 150° ; at 5:30, 15° .

A goal for your best students is to find the angle at completely arbitrary times such as 1:23. At that time, the hour hand has moved $\frac{23}{60}$ of 30° from the 1, so it makes a 41.5° angle with the 12. The minute hand has moved $\frac{23}{60}$ of 360° from the 12, so it makes a 138° angle with the 12. So the angle between the hands is $138 - 41.5 = 96.5^\circ$.

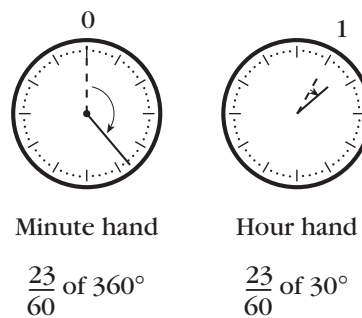

Discussion Answers

- 30° ; 0.5°
- 360° ; 6°

Lab 1.4: Angles of Pattern Block Polygons

Prerequisites: Lab 1.2 (Angle Measurement) is recommended.

The main purpose of this lab is to practice using angle measurements in the context of a broader problem. It also introduces the idea that the sum of the angles in a polygon is a function of the number of sides. Students should express their understanding of this in the summary.

In Problems 3–6, the angles we are adding are the angles of the polygon, not all the angles in the constituent pattern blocks. To clarify this, you may show the figure at right on the overhead.

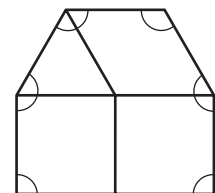

For this pattern block hexagon, add only the marked angles, excluding the six unmarked pattern block angles. Starting at the bottom left and proceeding clockwise, the sum of the polygon angles is $90 + (90 + 60) + (60 + 60) + 120 + (60 + 90) + 90 = 720^\circ$.

If students have trouble with Problems 7–9, give hints and encourage cooperative work. Resist the temptation to reveal the formula prematurely, as this often has the effect of decreasing students' motivation and intellectual engagement. Instead, let students use whatever method they can to solve the problems. If they cannot solve them, tell them that this idea will be reviewed in future lessons. There will be plenty of time to teach the formula then if you think that is important.

Answers

- Green: 180° ; red, blue, tan, orange: 360° ; yellow: 720°
- The four-sided shapes have the same sum.
- Polygons will vary, but will be six-sided.
- Polygons will vary, but will be five-sided.
- Answers will vary.
- Student sketches will vary. Angle sums in table should be 180° , 360° , 540° , 720° , 900° , 1080° , 1260° , 1440° , 1620° , 1800° .
- 3240° . Explanations will vary.
25. Explanations will vary.
- This is impossible because 450 is not a multiple of 180.
- To get the sum of the angles, subtract 2 from the number of sides and multiply by 180.
 $S = (n - 2)180$.

Lab 1.5: Angles in a Triangle

This is a “getting ready” activity, which will help prepare students for the following several labs.

Prerequisites:

Definitions:

acute, *right*, and *obtuse* angles;
equilateral, *isosceles*, and *scalene* triangles.

Theorems:

The angles of a triangle add up to 180° .

The base angles of an isosceles triangle are equal.

All angles of an equilateral triangle are equal.

If students are familiar with the theorems listed above, you could assign this page as homework.

If students are not familiar with the theorems, you may introduce them informally as described below.

- Have students cut three paper triangles—obtuse, right, and acute—from unlined paper (preferably colored paper).



Then, have them show by tearing and rearranging the angles of each triangle that they add up to 180° . (They can paste the torn and rearranged angles in their notebooks.)

- Hand out a sheet with several triangles on it. Have the students cut out the isosceles triangles on one copy of the sheet and verify that they can superimpose them onto themselves after flipping them over. This verifies that the base angles are equal. Similarly, they can flip and rotate the equilateral triangle in a variety of ways.

You could mention to students that they could find many additional triangles on the template by using two consecutive sides of other polygons and connecting them.

Answers

- No. There needs to be a third angle, and the sum of two right angles or two obtuse angles is already equal to or greater than 180° .
- $60^\circ, 60^\circ, 60^\circ$
 - Answers will vary. The angles should all be less than 90° . Two should be equal.
 - $45^\circ, 45^\circ, 90^\circ$

- d. Answers will vary. One angle should be greater than 90° . The other two should be equal.
 - e. Answers will vary. All angles should be less than 90° . None should be equal.
 - f. Answers will vary. One angle should be 90° . None should be equal.
 - g. Answers will vary. One angle should be greater than 90° . None should be equal.
3. $30^\circ, 60^\circ, 90^\circ$
 4. Right isosceles
 5. In an equilateral triangle the angles are all 60° , so they are not right or obtuse.
 6. The right triangles: c and f
 7. Answers will vary.
 8. In a right triangle, the two acute angles *add up to* 90° .
 9. See student work.

Lab 1.6: The Exterior Angle Theorem

Prerequisites: Students should know that the sum of the angles in a triangle is 180° .

You can use this activity to preview, introduce, or review the exterior angle theorem. It is a “getting ready” activity, which will help prepare your students for the next lab.

At the very beginning of the activity, make sure students understand the definition of exterior angle. You may use Questions A–C. Another way to get this across, which ties in with some of the labs in Section 3, is to point out that the exterior angle is the turn angle for someone who is walking around a triangle.

Some students may not have the mathematical maturity to really internalize an algebraic understanding of this and will rely instead on a sense of what is happening with the numbers. This is why Problems 4–6 and Questions D and E are important in laying the groundwork for understanding the theorem. Writing explanations for Problems 6c–9 should help cement what understanding is there.

Problem 10 is challenging, though students with a more developed algebraic sense should have no trouble with it. Another approach to it is based on the “walking polygons” approach mentioned above (and detailed in Section 3).

Answers

1. $80^\circ, 100^\circ$
2. Answers will vary.
3. Answers will vary, but one of them will always be 100° .
4. a. 115°
b. 65°
5. a. 115°
b. 65°
6. 123° in all cases. Explanations will vary.
7. x° . Explanations will vary.
8. An exterior angle of a triangle is always equal to *the sum of the two nonadjacent interior angles*. Explanations will vary.
9. 90° . Yes. It follows from the fact that the exterior angle at the right angle is also a right angle.
10. a. Always 360°
b. Explanations will vary.

Discussion Answers

- A. Three pairs of two or six altogether
- B. 180°
- C. See student work.
- D. Obtuse. In Problems 4 and 5, the exterior angle is acute, so the corresponding interior angle is obtuse. In Problem 6a, $\angle C = 113^\circ$; in 6b, $\angle C = 103^\circ$.
- E. x° and $(50 - x)^\circ$; sum: 50°

Lab 1.7: Angles and Triangles in a Circle

Prerequisites:

Definitions:

circle and *radius*.

Theorems:

- triangle sum theorem,
- isosceles triangle theorem,
- exterior angle theorem.

This is an extension that involves a lot of work and is probably most appropriate in a high school geometry course, in preparation for the inscribed angle theorem and its proof. However, this lab can be valuable even with less ambitious goals, such as developing a feel for the different types of triangles; providing an interesting experience in using the three theorems listed above; and discovering Thales's theorem (any angle inscribed in a half-circle is a right angle). In that case, it is sufficient to stop when most students have finished Problem 4, and perhaps Problem 5.

Problems 6 and 7 are mostly designed to prepare students for understanding the general proof of the inscribed angle theorem. Instead of doing them now, you may return to these problems later, perhaps with only circle geoboard paper rather than actual geoboards. You can even return to actual geoboards *after* students know the inscribed angle theorem, as an interesting way to practice applying the theorem.

Timing: This lab will take more than one period. Depending on how much discussion time you want to include, it could take up to three periods. It may not be necessary for all students to do the activity to the very end. If you think your students are “getting the picture” or are getting tired of this, you may interrupt them at the end of the last period you want to spend on this lab for a wrap-up discussion of what was learned.

Answers

1, 2. Because all the radii of the circle are equal, only isosceles and equilateral triangles are possible. The angle at the center of the circle can be found by noticing that the angle between any two consecutive pegs is $360^\circ/24 = 15^\circ$. Since the triangle is isosceles, the other two angles are equal and can be obtained by subtracting the central angle from 180° and dividing by 2.

- 3, 4.** Drawing an additional radius from the center to the third vertex allows you to divide the triangle into two sub-triangles. Then, you can find the angles by using the same method as in Problem 1. Another, faster way to get there is with the exterior angle theorem, which allows you to use the fact that the central angle in one sub-triangle is exterior to the other sub-triangle and therefore equal to twice its noncentral angles.
- 5.** They are all right triangles. Proofs will vary. One way to do it is to observe that the central angles in the two sub-triangles add up to 180° . Since they are equal to twice the noncentral angles, those must add up to 90° .
- 6, 7.** Again, drawing additional radii is a good strategy.

Discussion Answers

- A, B, C, D.** See solution to Problems 1 and 2.
- E.** All triangles in Problem 6 are acute; all triangles in Problem 7 are obtuse.

Lab 1.8: The Intercepted Arc

Prerequisites: The previous lab (Angles and Triangles in a Circle) is recommended.

This activity is an extension that provides an additional step in preparing students for the formal proof of the inscribed angle theorem.

Many students find the definitions that open this activity extraordinarily difficult to understand. You may use this activity to preview or reinforce what they will learn from the introduction in the textbook.

Use the discussion questions and the circle geoboard to follow up on this activity. Encourage the students to use the theorem rather than resort to drawing additional radii and using the cumbersome methods from the previous lab.

Answers

1. Inscribed angle; central angle; intercepted arc
2. \widehat{AQ} for both

3. 25° . Explanations will vary.
4. $c = a/2$. This follows from the exterior angle theorem.
5. $\angle b = 90^\circ$; $\angle c = 25^\circ$; $\angle d = 45^\circ$; $\angle APB = 70^\circ$
6. Answers will vary.
7. $\angle APB = (1/2)\angle AOB$. Explanations will vary.
8. An inscribed angle is equal to half the corresponding central angle.
9. Because of the exterior angle theorem, $\angle c = (1/2)\angle a$ and $\angle d = (1/2)\angle b$. By adding these equations, you get $\angle c + \angle d = (1/2)\angle a + (1/2)\angle b$. Factoring yields $\angle c + \angle d = (1/2)(\angle a + \angle b)$. In other words, $\angle APB = (1/2)\angle AOB$.
10. Figures and proofs will vary. The proofs should be similar to the one in Problem 9, using subtraction instead of addition.

Discussion Answers

- A. $52.5^\circ, 75^\circ, 30^\circ, 67.5^\circ$
- B. Left: $22.5^\circ, 67.5^\circ, 90^\circ$. Right: $52.5^\circ, 60^\circ, 67.5^\circ$.
- C. $120^\circ, 60^\circ, 120^\circ$
- D. Use arcs of $90^\circ, 120^\circ$, and 150° . This will work, since they add up to 360° .

Lab 1.9: Tangents and Inscribed Angles

Prerequisites: The inscribed angle theorem

Two theorems about tangents are previewed (but not proved) here. This lab uses the circle geoboard, with which students are now comfortable, to seed these concepts. At this point, students probably do not need to actually use the physical geoboard, but if any of them want to, do not discourage that.

The best strategy for Problem 4 is to add and subtract known angles in order to find unknown ones.

Answers

1. a. \widehat{QA} , 15°
b. \widehat{QB} , 37.5°

- c. \widehat{QC} , 67.5°
d. \widehat{QD} , 82.5°
e. Explanations will vary.
2. a. \widehat{QP}
b. 90°
3. Perpendicular
4. Explanations will vary.
a. \widehat{EP} , 67.5°
b. \widehat{FP} , 37.5°
c. \widehat{GP} , 15°
d. \widehat{HGP} (or \widehat{HFP} , \widehat{HEP} , \widehat{HQP}), 105°
5. Each angle measurement is indeed half of the intercepted arc, which equals the corresponding central angle.

Lab 1.10: Soccer Angles

Prerequisites: The inscribed angle theorem

This activity serves as a review and a “real world” application of the inscribed angle theorem. Note that the word *locus* has been replaced by the word *location*. This has the advantage of not terrifying the students.

To discuss Questions C–E, you should hand out the Soccer Discussion sheet or make a transparency of it (or both).

The most difficult question by far is E. One way to think of it is to imagine two runners, W and C . As W runs down L_4 , C stays at the center of the corresponding shooting arc. Since W 's angle is half of C 's, W has a better shot whenever C has a better shot. However, there comes a point where C must start moving back away from the goal, thereby reducing his shooting angle. This point corresponds to the time both runners are at the same horizontal line.

A challenging follow-up is to locate that point precisely by compass and straightedge construction. Another is to calculate its distance from the goal line as a function of the distance between the two runners' lines.

Answers

- 1–5. See student work.
6. The one corresponding to the 90° shooting angle
7. See student work.
8. 80°
9. The shooting angle for a person standing at the center of a circle is double the shooting angle for a person standing on the circle itself.
10. It is where the line of centers meets the 90° arc.

Discussion Answers

- A. On the same circle, behind the goal
- B. See the answer to Problem 9.
- C. Where L_0 meets L_1
- D. Where L_2 meets the goal line
- E. On L_3 , it would be at the point of tangency with the 40° circle. On L_4 , it would be at the point of tangency with some shooting circle, with shooting angle between 20° and 30° . See teachers' notes above for an explanation.

2 Tangrams

Lab 2.1: Meet the Tangrams

Timing: This activity could take a whole period. (If you don't want to give it that much time, do not duplicate this sheet, but address the basic ideas in Problems 4–6 and Questions A and B without it before going on to the next lab.)

Hand out the tangrams, one bag per student. To avoid mixing up the sets, do not give the same color to neighbors. Tell them that there are seven pieces per set and warn that, at the end of class, seven pieces should find their way back into the bag. At first, you should allow your students to play freely with the tangrams. Students may try to match the given figures or create their own. Houses, trees, and rocket ships are not uncommon. Students may record favorite

designs by tracing the blocks. By tracing the outlines of their designs, students can create puzzles for their classmates to solve.

Some students may know how to make a square with all seven pieces, and others may want to try it. You should neither encourage nor discourage that activity. Emphasizing it too much early on can be demoralizing because it is quite difficult. You should discourage students from “giving away” the solution, which is shown for your reference.

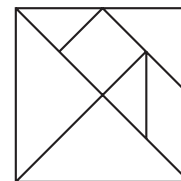

In Problem 4, make sure the students recognize that all five triangles are half-squares (isosceles right triangles). Introduce the word *parallelogram* and its spelling.

Understanding that the parallelogram is *not* flip-symmetric (see Problem 5) is sometimes the key to solving difficult tangram puzzles.

Question A hints at the notion of similarity. We will come back to this in Section 10, but if your students have already been exposed to this concept, you can ask them to make pairs of similar figures using tangrams. The figures below are examples.



Answers

1. 7
2. See student work.
3. See student work.
4. Five right isosceles triangles, one square, and one parallelogram
5. All do except the parallelogram.
6. Triangles: 45° , 90° ; square: 90° ; parallelogram: 45° , 135°
7. Answers will vary.

Discussion Answers

- A. They have the same shape but come in three different sizes. They are similar.
- B. Two small triangles can be combined to make a square or a parallelogram.
- C. Triangles: 360° , a whole circle; square: 90° , a quarter circle; parallelogram: 180° , a half circle
- D. The figure is reorganized to produce a foot. Note that the figure with a foot has a slightly shorter body and smaller belly.

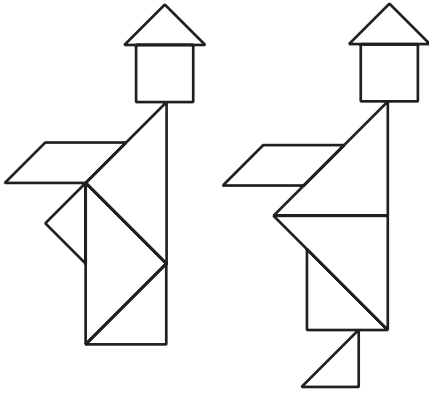

Lab 2.2: Tangram Measurements

This is a preview of an essential idea: the geometric interpretation of the square root. Understanding this idea makes it possible to solve the problem of finding all the tangram measurements. More important, it lays a foundation for a deeper understanding of square roots and their arithmetic than is possible from algebraic arguments alone. We will return to this with more detail and generality in Section 9.

Note that the Pythagorean theorem is not required for this lab.

In most classes, few students will be able to complete Problem 1 without the help of the questions in Problems 2–5. In fact, even after answering those questions, students may still need help. For example, the notation $2\sqrt{2}$ for the sides of the large triangles will not spontaneously occur to most students. Be prepared to introduce it and explain it.

Problem 7 can be assigned as an assessment of this lab.

All the discussion questions are difficult and deserve some time:

- Question A focuses on another important payoff of this lab: an understanding of the dimensions of the isosceles right triangle.
- Question B is a preview of similarity and scaling, which we will return to in Section 10.
- Question C gets at the idea—not at all obvious—that $2\sqrt{2} = \sqrt{8}$. The left side of that equation comes from measuring a leg of the large triangle with the legs of the small triangles. The right side comes from an argument about area similar to the one used in the lab to establish the length of a side of the square. You will find more on this subject in Section 9.

Of course, do not expect ideas such as these to be learned in a single lab. This activity is intended to complement, not replace, other approaches to these topics.

Answers

1. See answer to Problem 6 below.
2. a. 2 in.
b. 2 sq in.
c. 1 sq in.
d. 2 sq in.
3. a. 81 sq units
b. 3 units
c. 25 sq units
d. $\sqrt{5}$ units
4. a. s^2 sq units
b. \sqrt{A} units
5. $\sqrt{2}$ units
6. Small triangle sides: $\sqrt{2}$ in., 2 in. Area: 1 sq in.
Medium triangle sides: 2, $2\sqrt{2}$ in. Area: 2 sq in.
Square sides: $\sqrt{2}$ in. Area: 2 sq in.
Parallelogram sides: $\sqrt{2}$ in., 2 in. Area: 2 sq in.
Large triangle sides: $2\sqrt{2}$ in., 4 in. Area: 4 sq in.

7. Answers will vary.

Discussion Answers

A. $\sqrt{2}$

B. $\sqrt{2}, \sqrt{2}, 2$

C. 8 sq in.; $\sqrt{8} = 2\sqrt{2}$

Lab 2.3: Tangram Polygons

Timing: This activity could take one or two periods.

Part of the purpose is for students to develop their polygon vocabulary. The other part is to develop their visual sense, particularly to give them some experience with 45° angles and right isosceles triangles. Students who want to continue working on it beyond the allotted class time should be able to get extra credit or some sort of recognition for this. (You may set up a bulletin board display of the chart, in which you enter the names of students who solve a given puzzle.)

One way to organize this activity is explained below.

- Every time the students make a geometric figure, they quietly raise their hands. When you inspect their solutions, have them point to the appropriate space in their charts, indicating, for example, a three-piece triangle. If they are correct, initial that space. Some students may ask for more than one initial per space if they found different ways to solve a given problem. Some students may want you to check several spaces in succession before you leave to check other students' solutions.
- Help them label more lines in the chart beyond the initial three. If a student makes a three-piece rectangle, suggest starting a new row for rectangles. As more figures are found, you can update a list on the overhead or chalkboard so that other students can add to their sheets. Possible polygons include: rectangle, isosceles trapezoid, right trapezoid, pentagon, and hexagon.

This recording method is very hectic at first, as students start by finding easy solutions, but it

gradually slows down as they start tackling more substantial challenges. Of course, you could simplify your life by having students check their own puzzles and by entering the names of the other polygons into the chart before duplicating it for the class. The reason I follow the above procedure is threefold:

- Students are not tempted to check off solutions they have not found.
- Getting your initial is more satisfying to many of them than their own check mark.
- Immature competition with classmates is curtailed because students' charts are individual, exhibiting different polygons or the same polygons in different order.

Many students set their own subgoals, such as finding all triangles or all figures that can be made with two, three, or seven pieces.

Note: The five-piece square turns out to be an important ingredient in solving some of the larger puzzles.

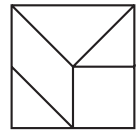

Answers

Answers will vary. See student tables and observe students as they work.

Discussion Answers

A. Answers will vary.

B. A single tangram piece has area 1, 2, or 4. All of them together have an area of 16. Therefore, a six-piece figure must have area 15, 14, or 12. It follows that a six-piece square is impossible, since its side would have to be the square root of one of these numbers. This is not possible given the measurements of the tangram pieces.

Lab 2.4: Symmetric Polygons

Prerequisites: Students need to have some familiarity with the concept of symmetry. If they do not, wait until you have done the opening lab of Section 5 before doing this one.

Problems 1 and 2 offer a good opportunity to think about what makes a figure symmetric.

The solutions to Problem 3 may well overlap with solutions found in Labs 2.1 (Meet the Tangrams) and 2.3 (Tangram Polygons).

If you are short on time, skip this problem.

One approach to Question B is to work backward, starting from a symmetric figure and removing some pieces.

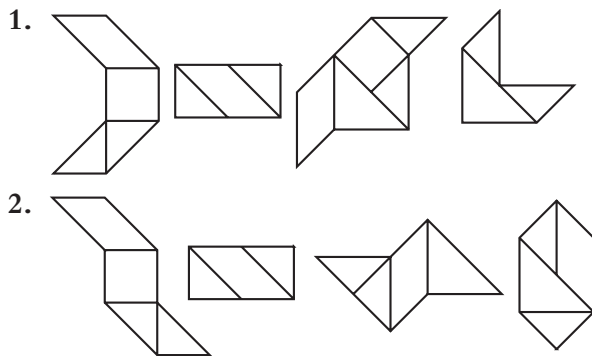

3. Answers will vary.

Discussion Answers

- A. Answers will vary.
- B. Answers will vary.
- C. Yes. See the second and fourth figures in Problem 2, for example.

Lab 2.5: Convex Polygons

The formal definition of convex is:

A figure is convex if the segment joining any two points on it lies entirely inside or on the figure.

However, it is not necessary for students to understand this at this stage in their mathematical careers.

Problem 5 is quite open-ended. Its solutions overlap the ones found in Lab 2.3 (Tangram Polygons), but it is more difficult in some cases because convexity was not previously an issue.

Students probably have their own opinions on the aesthetics and difficulty of tangram puzzles. As I see it, there are three types of puzzles that are particularly pleasing:

- symmetric puzzles
- convex puzzles
- puzzles that use all seven pieces

The classic seven-piece-square puzzle satisfies all of these requirements. As for difficulty, it seems to also be related to convexity: If a figure has many parts “sticking out,” it is easier to solve.

Extensions: Two classic seven-piece puzzle challenges are mentioned in Martin Gardner’s book *Time Travel and Other Mathematical Bewilderment*.

- The more elegant of the two puzzles is to find all 13 seven-piece convex figures, which is mentioned in this lab as part of Problem 5.
- The other puzzle is to find as many seven-piece pentagons as possible.

Both challenges are very difficult and should not be required. I suggest using the first as an optional contest, displaying solutions on a public bulletin board as students turn them in, and perhaps offering extra credit. If this turns out to be a highly successful activity, you can follow it up with the other challenge. Do not tell students that there are 53 solutions to the pentagon challenge, as that would seem overwhelming. Instead, keep the search open as long as students are interested. The solutions can be found in Gardner’s book.

Answers

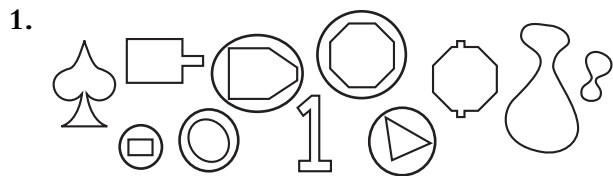

2–5. Answers will vary. See student work.

3 Polygons

Lab 3.1: Triangles from Sides

Prerequisites: This is the first construction activity in this book. It assumes that you have taught your students how to copy segments with a

compass and straightedge. You may also use other construction tools, such as the Mira, patty paper (see next paragraph), or computer software. This lab, and most of the other construction labs, can be readily adapted to those tools or to some combination of them.

Patty paper is the paper used in some restaurants to separate hamburger patties. It is inexpensive and is available in restaurant supply stores and from Key Curriculum Press. It is transparent, can be written on, and leaves clear lines when folded. These features make it ideal for use in geometry class, as tracing and folding are intuitively much more understandable than the traditional compass and straightedge techniques. In my classes, I tend to use patty paper as a complement to a compass and straightedge, rather than as a replacement. (I learned about patty paper from Michael Serra. See his book *Patty Paper Geometry*.)

In content, the lab focuses on the Triangle Inequality. It is a useful preview of the concept of congruent triangles as well as a good introduction to the use of basic construction techniques.

Answers

1. See student work.
2. Answers will vary.
3. Sides a and b are too small, so they cannot reach each other if e is the third side.
4. **Possible:** $aaa, aab, abb, acc, add, ade, aee, bbb, bbc, bcc, bcd, bdd, bde, bee, cc, ccd, cce, cdd, cde, cee, ddd, dde, dee, eee$
Impossible: $aac, aad, aae, abc, abd, abe, acd, ace, bbd, bbe, bce$

Discussion Answers

- A. No. Since $2 + 4$ does not add up to more than 8.5, the two short sides would not reach each other.
- B. No. Since $2 + 1.5$ does not add up to more than 4, the two short sides would not reach each other.
- C. It must be greater than 2 and less than 6.

- D. The two short sides add up to more than the long side. Or: Any side is greater than the difference of the other two and less than their sum. (This is known as the Triangle Inequality.)

Lab 3.2: Triangles from Angles

Prerequisites: This lab assumes that you have taught your students how to copy angles with a compass and straightedge. As with the previous lab, you may also use other construction tools, such as the Mira, patty paper, or computer software. This lab, and most of the other construction labs, can be readily adapted to those tools or to some combination of them.

This lab reviews the sum of the angles of a triangle. It previews the concept of similar triangles and introduces basic construction techniques.

If it is appropriate for your class at this time, you may discuss the question of similar versus congruent triangles. The triangles constructed in this lab have a given shape (which is determined by the angles), but not a given size, since no side lengths are given. You could say that the constructions in the previous lab were based on SSS (three pairs of equal sides), while the ones in this lab are based on AAA, or actually AA (two—and therefore three—pairs of equal angles). SSS guarantees congruent triangles: All students will construct identical triangles. AA guarantees similar triangles: All students will construct triangles that have the same shape, but not necessarily the same size.

Answers

1. See student work.
2. Answers will vary.
3. No. The sides would not intersect.
4. **Possible:** Triangles can be constructed using the following pairs of angles: 1,1; 1,2; 1,3; 1,4; 1,5; 2,2; 2,3.
Impossible: Triangles cannot be constructed using the following pairs of angles: 2,4; 2,5; 3,3; 3,4; 3,5; 4,4; 4,5; 5,5.

Discussion Answers

- A. No. It's only possible if they add up to 180° .
- B. They must add up to less than 180° .
- C. **Method 1:** Construct a triangle that has those two angles. The third angle is the required size.

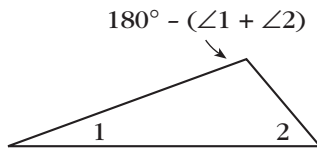

Method 2: Construct a copy of one of the angles so it is adjacent to the other. Extend either nonshared side to form a third angle, which, added to the first two, forms a straight line.

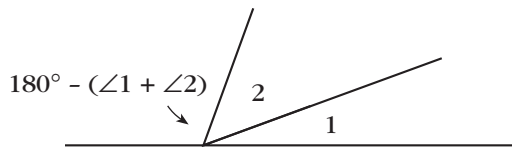

Lab 3.3: Walking Convex Polygons

The definition of convex polygon given here—a convex polygon is one where no angle is greater than 180° —is equivalent to this more formal one, given in the Notes to Lab 2.5 (Convex Polygons): A figure is convex if the segment joining any two points on it lies entirely inside or on the figure. You can convince yourself of this by drawing a few pictures. It is not necessary to discuss this with your students; they will be glad to accept the equivalence without proof. The alternate definition is provided here in case you skipped Lab 2.5 and you need a definition that is easy to grasp so you can get on with the work at hand. (See the introduction to Section 1 for some notes on angles greater than 180° .)

Some of the solutions to Problem 3 are quite difficult to find. It is not crucial for all students to find every one; you may ask them to work on

this in groups. The main point of the exploration is to make sure students understand the definition of a convex polygon.

Solutions to this puzzle can be beautiful, and you may want to display them on a bulletin board. Students who enjoy this challenge can be given additional constraints: It's possible to solve the puzzle using only squares and triangles. Another challenge could be to use as many tan pattern blocks as possible, or to find alternative solutions for each n -gon.

The exterior angle was introduced for triangles in Lab 1.6 (The Exterior Angle Theorem), but that lab is not a prerequisite to this one.

Make sure students understand the example of walking the trapezoid before letting them work on other figures. You may have a student demonstrate the walk in a figure like the one on the sheet, while another records each step on the board or overhead projector.

If the trapezoid instructions start in the middle of a side, as suggested in Question A, all turn angles must be included in order to finish the walk. This provides another reason for including the final turn in the “normal” walks that start at a vertex: This way, all versions of the walk include the same angles.

Answers

1. No. All three angles combined add up to 180° , so one angle alone cannot be greater than 180° .
2. Yes. Figures will vary.

3. Answers will vary. Here are some possibilities.

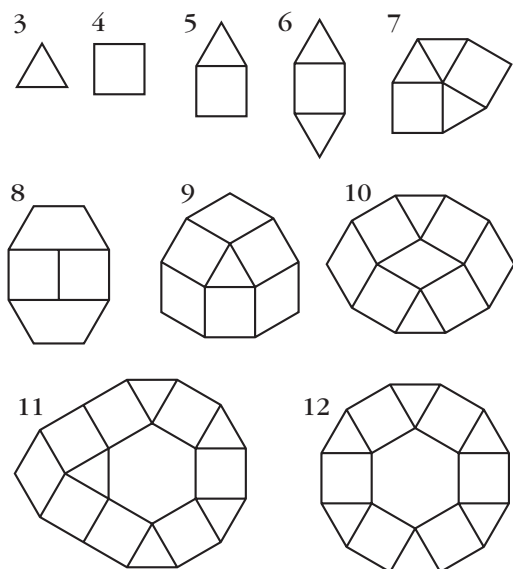

4. See figure below.

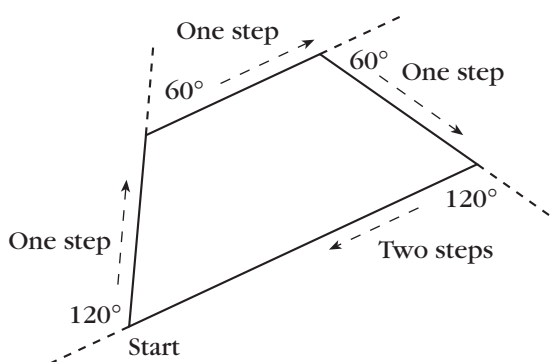

5. Answers will vary.

6. Answers will vary.

7. No written answer is required.

8. Answers will vary.

Discussion Answers

A. Answers will vary.

B. They are supplementary. They are equal if they are right angles.

C. In a clockwise walk, you turn right. In a counterclockwise walk, you turn left.

Lab 3.4: Regular Polygons and Stars

Prerequisites: Students should know how to find the measure of an inscribed angle given its intercepted arc. See Lab 1.7 (Angles and Triangles in a Circle) and Lab 1.8 (The Intercepted Arc).

To make sure students understand the definition of regular polygons, you may put a few pattern blocks on the overhead before handing out the geoboards, and precede the lab with a discussion of Questions A–C.

You may do this activity without actual geoboards or string by just using the circle geoboard paper on page 243. But it's fun to make at least a few of the stars on the geoboard using string. If you do use string, you will need to provide each student or pair of students with a string that is at least 5 or 6 feet long. For Question J, students can use the template's regular 10-gon to mark the vertices of the imaginary ten-peg circle geoboard. (In fact, students can use the template's regular polygons to investigate stars further.)

Questions E–J lead into a number of theoretic discussions about such things as common factors. Question I helps students generalize the calculation that they have to do while filling in the table. Questions J–L are wide-open opportunities to extend student research into this domain and could be the starting points of interesting independent or small-group projects.

Answers

- Equilateral; square
- A hexagon
 - 120°
- An eight-pointed star; 45°

4.

Every p -th peg	Star or polygon?	Number of sides	Angle measure
1	polygon	24	165°
2	polygon	12	150°
3	polygon	8	135°
4	polygon	6	120°
5	star	24	105°
6	polygon	4	90°
7	star	24	75°
8	polygon	3	60°
9	star	8	45°
10	star	12	30°
11	star	24	15°
12*	neither	2	0°
13	star	24	15°
14	star	12	30°
15	star	8	45°
16	polygon	3	60°
17	star	24	75°
18	polygon	4	90°
19	star	24	105°
20	polygon	6	120°
21	polygon	8	135°
22	polygon	12	150°
23	polygon	24	165°
24*	neither	0	180°

*Accept different reasonable answers for these rows and encourage students to defend their answers. See answer to Question G below.

Discussion Answers

- A. Triangle, square, hexagon
- B. The angles are not all equal.
- C. Answers will vary.

- D. Answers will vary.
- E. You get a polygon only if p is a factor of 24 (excluding 12 and 24; see Question G).
- F. Connecting every eleventh peg (or thirteenth peg) requires the most string because this produces a 24-sided star in which each side is nearly the diameter of the geoboard. Connecting every ninth peg (or fifteenth peg) requires the least string because this produces a star with only eight sides.
- G. When $p = 12$ or $p = 24$, the figure would have two overlapping sides, or none, which would not be enough sides for either a polygon or a star. It is possible to find the angles by extending the patterns that are apparent in the other rows.
- H. Every interval of p pegs counterclockwise is the same as an interval of $24 - p$ pegs clockwise.
 - I. $180^\circ - 15p$
 - J. See student work.
 - K. Values of p that are factors of n will produce a polygon. Other values of p produce stars.
 - L. Answers will vary.

Lab 3.5: Walking Regular Polygons

Prerequisites: Students need to be familiar with the definition of interior versus exterior angles. These concepts were introduced in Lab 1.6 (The Exterior Angle Theorem) and Lab 3.3 (Walking Convex Polygons).

Actual students wrote the three samples at the beginning of the lab. You may try to work from samples written by your students. The first instruction is ambiguous and could be clarified either by writing “Turn 90° left and take a step. Repeat four times.” or by using parentheses, as Maya did.

Students will probably not need to physically walk these shapes. If they did Lab 3.3 (Walking Convex Polygons), they should have little trouble doing the “walking” on paper. The essential idea,

which Question B hints at, is that by the time you have walked all around the polygon, your total turning is 360° . All the other calculations follow easily from this fact.

If you use spreadsheets or graphing calculators, you can have students use them to complete the table; however, that requires figuring out the formulas. Another approach is to finish Problem 6 on paper, then extend the table by using technology.

Question C: The angle sum formula that flows from Problem 6 is $n(180^\circ - 360^\circ/n)$. This simplifies to $180^\circ n - 360^\circ$, which can be factored to the traditional $180^\circ(n - 2)$.

Question D can be the starting point of an ambitious mathematical research project for a student, group, or class.

If you have access to the Logo computer language, your students may follow up this activity with the equivalent one on the computer. There, they can explore many variations of polygon walks. (See almost any of the books on Logo.) For further investigations, you could have students use Logo to write procedures to draw each of the pattern blocks. A more advanced project is to combine such procedures to create pattern block designs on the screen.

Answers

- Jenny: instructions are ambiguous; Maya: 360° ; Pat: 270°
- $(\text{Take step, turn right } 120^\circ) \cdot 3$
- 360°
- The interior angles
 - The exterior angles
- Since the polygon is regular, all interior angles are equal. Therefore, all exterior angles are equal, and each is equal to the total turning divided by 7. So each exterior angle is $360^\circ/7$, or approximately 51.43° .
 - Each interior angle is the supplement of the corresponding exterior angle. In this case, it is $180^\circ - 51.43^\circ = 128.57^\circ$.

6.

Number of sides	Each angle	Angles sum	Turn angle	Total turning
3	60°	180°	120°	360°
4	90°	360°	90°	360°
5	108°	540°	72°	360°
6	120°	720°	60°	360°
7	128.57°	900°	51.43°	360°
8	135°	$1,080^\circ$	45°	360°
9	140°	$1,260^\circ$	40°	360°
10	144°	$1,440^\circ$	36°	360°
11	147.27°	$1,620^\circ$	32.73°	360°
12	150°	$1,800^\circ$	30°	360°
100	176.4°	$17,640^\circ$	3.6°	360°
n	$180^\circ - \frac{360^\circ}{n}$	$n(180^\circ - \frac{360^\circ}{n})$	$\frac{360^\circ}{n}$	360°

Discussion Answers

- Jenny's instructions are ambiguous. The other two will yield a square.
 - They all involve taking steps and turning 90° .
 - Maya's involve four turns; Pat's only three.
 - Answers will vary.
 - Answers will vary.
- Students should agree that total turning is easiest to find, since it's always 360° . From there you can get the turn angle, the interior angle, and the angles sum, in that order. (See the formulas in the table above.)
- Answers will vary.
- Answers will vary.

Lab 3.6: Walking Nonconvex Polygons

To walk a nonconvex polygon requires at least one turn to be in a different direction from the others. For example, in the figure below, there are three right turns and one left turn if you go clockwise around the figure.

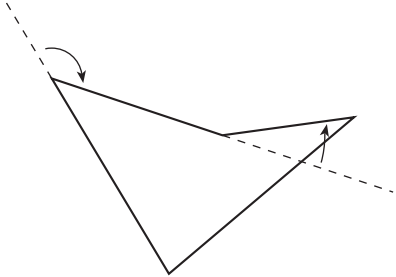

This leads to interesting questions about how to add the angles and still get 360° . You may ask the students to do Problems 1 and 2 and discuss Question A before handing out the sheet.

The idea of *heading*, introduced in Problem 2, gives a conceptual anchor to the idea of positive and negative turns. If you are complementing the walking lessons with work in the Logo computer language, you should be aware that in this lesson heading is defined the same way as in Logo: In Logo, there are no references to compass directions, but 0° is toward the top of the screen, 90° is toward the right, and so on.

Answers

- Answers will vary.
 - No written answer is required.
- 360°
 - Answers will vary.
 - Answers will vary.
- 180°
 - 270°
 - 225°
 - 337.5°
- 192°
 - 303°
 - $180^\circ + h^\circ$. If the answer is greater than 360° , subtract 360° .

- See answer to 4c.
- Add 360° to get the corresponding positive heading.
- Answers will vary.
- Left turns subtract; right turns add.
- If you consider right turns to be positive and left turns to be negative, the total turning should be 360° (assuming you are walking in an overall clockwise direction).

Discussion Answers

- See answer to Problem 9 above.
- Turning 360° brings your heading back to what it was when you started. If you turn 350° , you have turned 10° less than all the way around, which is the same as turning -10° .
- Right $-90^\circ =$ left $90^\circ =$ right 270°
- Clockwise

Lab 3.7: Diagonals

In Problem 3, encourage students to come up with a systematic method for counting. One way, which you may suggest if they are getting frustrated, is to count the number of diagonals out of one vertex, then count the number of *new* diagonals out of the next vertex (one less), and so on.

One way to get at the formula, which you may suggest as a complement to your students' approaches, is to connect each vertex to all other vertices not adjacent to it. In an n -gon, there are $n - 3$ vertices that are nonadjacent to any given vertex; so there are $n - 3$ diagonals per vertex, for a total of $n(n - 3)$. However, this method counts every diagonal twice, once at each end. Therefore, the actual number is $n(n - 3)/2$. This reasoning is relevant to Problems 3–5.

To help students understand the comment following Problem 4, you should probably show examples of external diagonals in nonconvex polygons on the overhead or chalkboard.

To make an algebra connection, you may have the students make a graph of the data in Problem 3. When they find the formula, they may use a graphing calculator to see that the graph actually does go through the data points.

The discussion in Problems 5–7 continues a thread we started in Lab 1.4 (Angles of Pattern Block Polygons) and continued in Lab 3.5 (Walking Regular Polygons). Here we present a traditional approach to finding the sum, but it requires the polygon to be convex.

Answers

- 0
- 2

3.

Sides	Diagonals	Sides	Diagonals
3	0	7	14
4	2	8	20
5	5	9	27
6	9	100	4850

- $\frac{n(n-3)}{2}$
- $n - 2$
- $(n - 2)180^\circ$
- External diagonals do not divide the polygon into triangles.

Discussion Answers

- Successive differences in the numbers of diagonals are 2, 3, 4, and so on.
- A polygon is convex if all of its diagonals are on the inside of it.

Lab 3.8: Sum of the Angles in a Polygon

This is another lesson on the same topic. The point of these multiple approaches is not so much to stress the formula—which is not in itself earth-shatteringly important—but it is interesting to see that there are many avenues to get to it. Since this lab requires no materials and travels familiar territory, it could be done as homework.

Answers

- Answers will vary.
 - Answers will vary.
 - 720°
 - 360°
 - 360°
- $540^\circ, 720^\circ, 1080^\circ, 1800^\circ$
 - $180^\circ n - 360^\circ$
- The procedure fails because no interior point can be connected to all the vertices.
- Answers will vary.
- The sum should be 900° .

Discussion Answer

- This method uses two more triangles but yields the same formula.

Lab 3.9: Triangulating Polygons

If your students are familiar with Euler's formula for networks ($E = V + F - 1$, where V , F , and E are the number of vertices, "faces" [that is, undivided polygons], and edges, respectively), you may investigate the relationship between that formula and the one in this exploration.

Lead a discussion of Question D. One possible answer is that the sum of the angles in a polygon can be found by triangulating it. In fact, that is the method we used in the previous two activities, but only now do we have a method general enough to work for any polygon, convex or not.

Duane W. DeTemple and Dean A. Walker describe an interesting set of activities that make use of polygon triangulation in "Some Colorful Mathematics" (*The Mathematics Teacher*, April 1996, p. 307).

Answers

The following answers correspond to the list of research questions.

- One triangle is added each time you add a side.
- Adding an inside vertex adds two triangles.

- Adding a side vertex adds one triangle.
- The relation can be expressed as $t = n - 2 + 2i + s$.

Discussion Answers

- A. No.
- B. A minimal triangulation might be defined as a triangulation that requires no additional vertices besides the vertices of the polygon. It can be sketched by drawing as many inside diagonals as possible, with the restriction that they should not intersect each other.
- C. Inside vertices add more triangles than do side vertices. Four original vertices, two side vertices, and two inside vertices will yield eight triangles, whereas the example with six original vertices, one inside vertex, and one side vertex yields only seven triangles. The additional triangle is a result of the additional inside vertex. If there are eight vertices, the way to get the least possible number of triangles is to make all eight vertices the original vertices of an octagon. Then there are only six triangles. The way to get the greatest possible number of triangles is to start with a triangle for the original shape and add five inside vertices. That gives a total of 11 triangles.
- D. Triangulation provides a method for calculating the sum of the angles in a polygon.

4 Polyominoes

Lab 4.1: Finding the Polyominoes

This lab is a prerequisite to all further work with polyominoes and pentominoes, since this is where we define our terms and discover and name the figures.

Throughout this section, use 1-Centimeter Grid Paper (see page 241).

The main difficulty is that students tend to discover the same pentominoes more than once. The best way to eliminate duplications is to make the polyominoes with the interlocking cubes. Then students can pick up, turn, and flip newly found pentominoes to check whether they are identical to shapes they have already found. To avoid finding 3-D shapes, I include the rule that when the figure is laid flat all of its cubes should touch the table. The 3-D version of this activity is polycubes (see below).

You will have to decide whether to reveal the total number of tetrominoes (five) and pentominoes (12) or to let your students discover them on their own. I have done both, depending on how much time I had for the activity and whether any of the students seemed ready for the somewhat more demanding task of developing a convincing argument that all the figures have been found.

Later in this section you will find other searches in the same style, though generally more difficult: hexominoes, polyrectangles, polycubes, and polyarcs.

Here are some suggestions for the alternative classification schemes referred to in Question B (you can find more later in the section):

- by perimeter (for these areas, the result would be almost the same as the classification by area, but not quite; see Section 8)
- by number of sides (interestingly, always an even number—why?)
- convex versus nonconvex (this reveals that the only convex polyominoes are rectangles)

After this lesson, you can hand out the Polyomino Names Reference Sheet that follows the lab. Encourage students not to lose their copies, as you may need to discuss the polyominoes with specific references to various names. (It is not, however, important to memorize the names.)

Answers

1. See Polyomino Names Reference Sheet.
2. See Polyomino Names Reference Sheet.

Discussion Answers

- A. Answers will vary.
- B. See notes above.
- C. F, L, N, T, W, X, Y, Z

Lab 4.2: Polyominoes and Symmetry

This lab is a preview of some of the ideas about symmetry discussed in Section 5, approached from the point of view of polyominoes. The use of a grid here makes it somewhat easier to introduce these ideas, but this lesson is not a prerequisite for Section 5.

If students find Problem 2 daunting (after all, there are 20 categories!), suggest that they go through the list of polyominoes (see Polyomino Names Reference Sheet) and find the appropriate category for each one. For most students, this would be easier than searching for all the polyominoes that fit in each category.

We come back to the question posed here in Lab 4.10 (Polyrectangles), Question C.

Answers

1. Monomino: 1
Domino: 2
Bent tromino: 4
Tetrominoes: square, 1; **l**, 8; **i**, 2; **n**, 4; **t**, 4
Pentominoes: **F**, 8; **L**, 8; **l**, 2; **P**, 8; **N**, 8; **T**, 4; **U**, 4; **V**, 4; **W**, 4; **X**, 1; **Y**, 8; **Z**, 4
2. a. No mirrors, no turns: tetromino **l**;
pentominoes **F**, **L**, **P**, **N**, **Y**
b. One mirror, no turns: bent tromino;
tetromino **t**; pentominoes **T**, **U**, **V**, **W**
c. Two mirrors, no turns: none
d. Three mirrors, no turns: none
e. Four mirrors, no turns: none
f. No mirrors, two-fold turn (180°):
tetromino **n**; pentomino **Z**

- g. One mirror, two-fold turn: none
h. Two mirrors, two-fold turn: domino;
straight tromino; tetromino **i**; pentomino **l**
i. Three mirrors, two-fold turn: none
j. Four mirrors, two-fold turn: none
k. No mirrors, three-fold turn (120°): none
l. One mirror, three-fold turn: none
m. Two mirrors, three-fold turn: none
n. Three mirrors, three-fold turn: none
o. Four mirrors, three-fold turn: none
p. No mirrors, four-fold turn (90°): none
q. One mirror, four-fold turn: none
r. Two mirrors, four-fold turn: none
s. Three mirrors, four-fold turn: none
t. Four mirrors, four-fold turn: monomino;
tetromino square; pentomino **X**

Discussion Answers

- A. Three-fold turns are impossible because all angles are 90° . Other impossible combinations are more difficult to explain; for example, if there are two mirrors, there has to be a turn.
- B. The more symmetric the shape, the fewer positions there are on graph paper.
- C. You would need to have backward versions of the tetromino **l** and the following pentominoes: **F**, **L**, **P**, **N**, **Y**.

Lab 4.3: Polyomino Puzzles

For Problem 2, you may choose to reveal that there are 25 such rectangles. For Problem 4, there are six such staircases.

Note that the area of a rectangle of the type requested in Problem 2 cannot be a prime number and that the process of finding the rectangles is equivalent to finding the factors of the nonprime numbers from 4 to 28.

Answers

1. See Polyomino Names Reference Sheet.

2, 3.

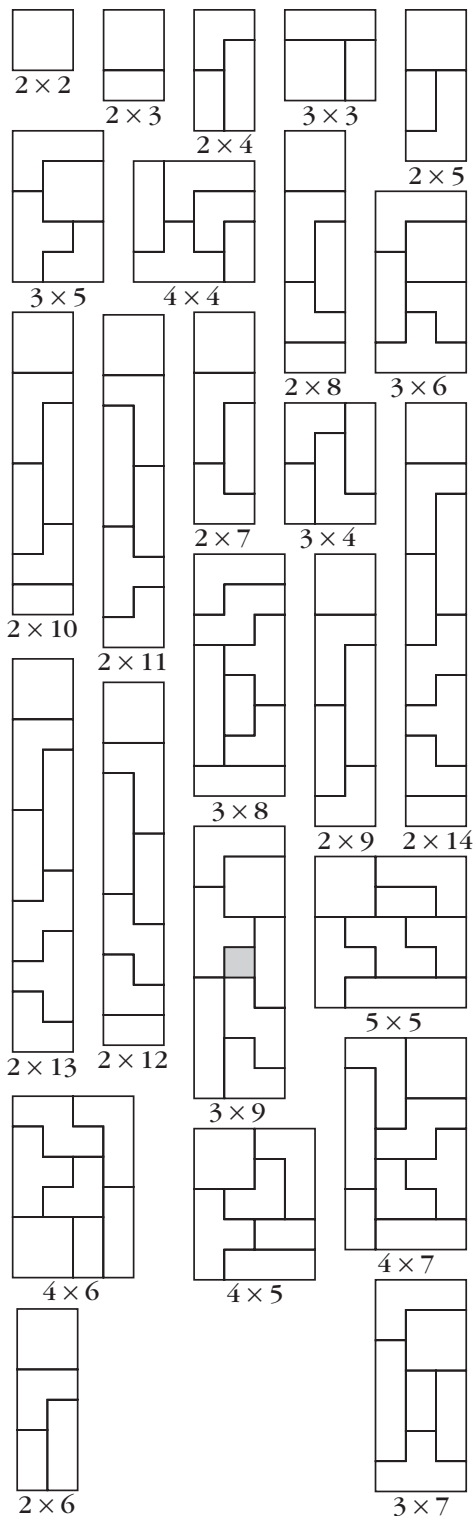

4.

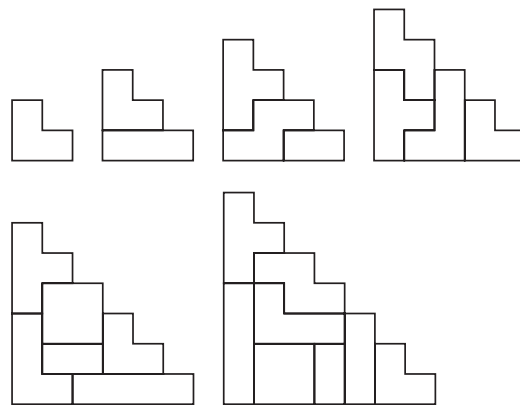

Discussion Answers

- A. Answers will vary.
- B. The 3×9 rectangle is impossible because its area is 1 less than the combined area of the allowed pieces. However, the piece with least area is the domino, and omitting it allows a maximum area of 26.
- C. Two such staircases can be combined to make an $x \times (x + 1)$ rectangle. So the area of one must be $x(x + 1)/2$.

Lab 4.4: Family Trees

Family trees and envelopes (see Lab 4.5) offer ways to make the search for hexominoes more systematic. In addition, they offer yet two more methods for classifying polyominoes.

If your students have studied probability, you could assign the following research project.

Imagine that a machine creates pentominoes with this algorithm: Start with a monomino and add squares randomly, with each possible location having an equal chance of being used. What is the probability of getting each pentomino? Which pentomino is the most likely? Which is the least likely?

It is interesting to note that the **P** pentomino is the most likely, which is perhaps related to the fact that it is most often the one you need in order to complete pentomino puzzles.

Answers

1.

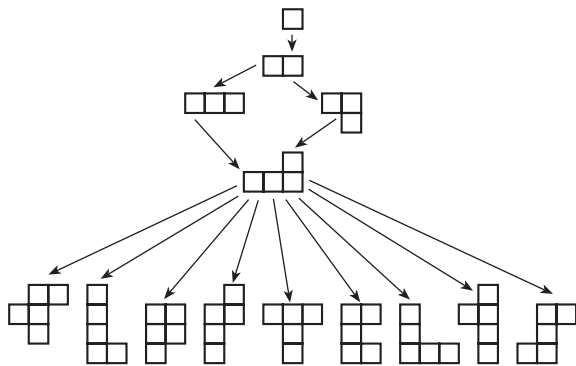

2.

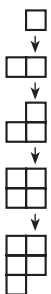

3.

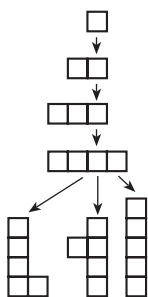

4.

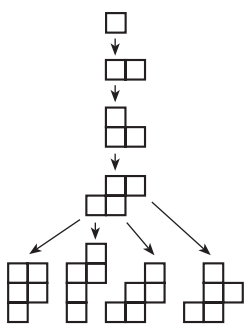

Discussion Answers

A. The P has four parents.

B. L and Y

C. F, N, P

D. Only the W

E. I and W

F. The L has 11 children.

G. The X has only two children.

Lab 4.5: Envelopes

If students are floundering on Problem 4, you may suggest that they organize their search with the help of the hexomino envelopes they found in Problem 3. Another useful approach is to use some sort of systematic process based on the family tree idea: Look for all of the children of each of the 12 pentominoes.

The advice given in Lab 4.1 (Finding the Polyominoes) still holds here.

Have students make the hexominoes with the interlocking cubes so that they can pick up, turn, and flip newly found hexominoes to check whether they are identical to shapes they have already found. Remind students that when the figure is laid flat all of its cubes should touch the table. The 3-D version of this activity is Lab 4.8 (Polycubes).

You will have to decide whether to reveal the total number of hexominoes (35) or to let your students discover it on their own. I have done both, depending on how much time I had for the activity and whether any of the students seem ready for the somewhat more demanding task of developing a convincing argument that all the figures have been found.

Because the task is so daunting, it is a good idea to work in cooperative groups. I have sometimes split the class into two groups (the boys against the girls!) and made this a race, but you may not have the tolerance for the level of noise and organized mayhem this may generate. If the groups are large, or even with normal-size groups of four, this is one exercise where it is important to have a student be responsible for record keeping. Among other things, this student must keep an eye out for duplicates!

It is not crucial that students find all 35 hexominoes, but they are likely to want to know if they were successful in their search. Use their curiosity as a springboard for the next lab, which should help them spot duplicates as well as find any missing hexominoes. In fact, if you do not want to spend too much time on this project, you may hand out the next lab early on.

Since there are 105 heptominoes, that search is probably best left to a computer.

Lab 4.7 (Minimum Covers) addresses a related question.

Answers

1. 1×4 : i
 2×2 : square
 3×2 : n, l, t
2. 1×5 : l
 2×3 : P, U
 2×4 : L, N, Y
 3×3 : F, T, V, W, X, Z

3. ~~2×2~~ ~~1×5~~ 2×3 2×5
 3×3 ~~3×5~~ 2×4 1×6
 3×4 ~~2×6~~ ~~4×4~~ ~~3×6~~

4. \checkmark = Can be folded into a cube

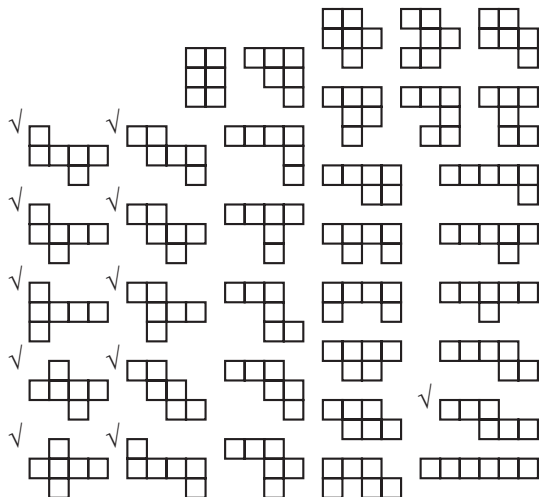

Discussion Answers

A. In most polyominoes, the number of vertical units on the perimeter equals twice the height of the envelope, and the number of horizontal units on the perimeter equals twice the width of the envelope. So the perimeter of the polyomino is equal to the perimeter of its envelope. For example, the **n** tetromino, oriented as shown below left, has 6 vertical units and 4 horizontal units along its perimeter. Its perimeter is 10, and its envelope is a 3×2 rectangle with perimeter 10. Polyominoes with “bays” in them can have perimeters greater than their envelopes. For example, the **U** pentomino has perimeter 12, but its envelope has perimeter 10. The perimeter around the inside of the “bay,” 3 units, corresponds to just 1 unit on the perimeter of the envelope. It’s not possible for a polyomino to have perimeter less than its envelope.

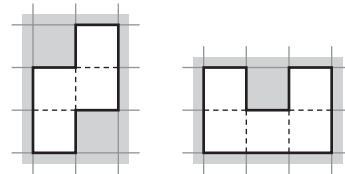

B. See check marks in the answer to Problem 4.

Lab 4.6: Classifying the Hexominoes

This lab is a sequel to Problem 4 in Lab 4.5. Students were asked to come up with envelopes and find hexominoes on their own, without knowing how many there are. This lab gives students the 35 hexomino envelopes, allowing them to check how they did in their search and to organize their findings. You can use this lab to speed up the investigation in Lab 4.5.

Answers

See answer to Problem 4, Lab 4.5.

Lab 4.7: Minimum Covers

This lab is a minimization problem, which should help students develop their visual sense. It is not very difficult once the question is clear.

Answers

1–3.

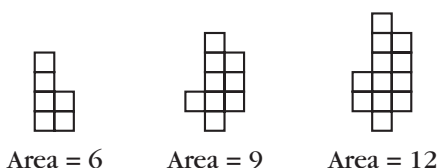

Discussion Answers

A. Answers will vary.

B. Other shapes are possible, though all minimum covers will have the same area. For example, this shape is also a minimum cover for tetrominoes.



Lab 4.8: Polycubes

For many students, it is difficult to realize that there are 3-D figures that are mirror images of each other yet cannot be superimposed onto each other. This is the case whenever the figures are not themselves mirror symmetric. This is unlike the situation in two dimensions, where (by way of a trip to the third dimension) a figure can be flipped and superimposed upon its mirror image.

Just as the canonical polyomino puzzle is to make a rectangle using a given set of polyominoes, the canonical polycube puzzle is to make a box using a given set of polycubes. In Problem 5, one necessary condition for a box to work as a pentacube puzzle is that its volume—and therefore at least one of its dimensions—must be a multiple of 5. Of course, that does not guarantee the puzzle can be solved (for example, a $1 \times 2 \times 5$ box cannot be made), but a solution can probably be found in almost every case, if we are to generalize from the case of pentominoes. This would be a good exploration for a student project.

To answer Questions C and D, students need to have done Lab 4.4 (Family Trees) and Lab 4.5 (Envelopes).

Look for other generalizations of polyominoes in the following two labs.

Answers

1. monocube: 

dicube: 

tricubes: 

tetracubes: 



2, 3. No answer is required.

4. There are 32 possible pentacubes, including the 12 pentomino shapes.

5. Answers will vary. See Notes above.

Discussion Answers

A. Answers will vary.

B. By symmetry, by volume, by surface area, by convexity. Other answers are possible.

C. The smallest rectangular box that encloses the given polyomino

D. Answers will vary.

Lab 4.9: Polytans

Problem 2 is challenging, and you should encourage group collaboration to help those students who are getting stuck. You need to decide whether to tell the class how many distinct 4-tan shapes there are (14) or whether instead to have them discuss Question B.

Plastic SuperTangrams™ are available commercially, as are some related puzzle books I authored: *SuperTangram Activities* (2 vols., Creative Publications, 1986).

Answers

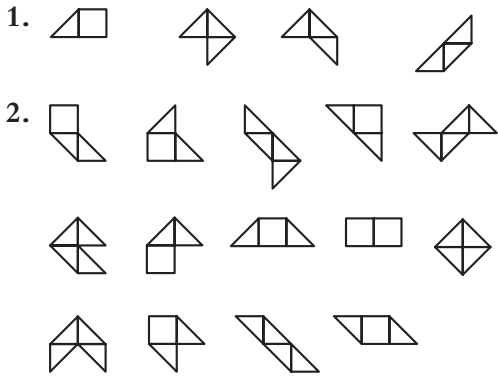

Discussion Answers

- A. Answers will vary.
- B. Answers will vary.
- C. The perimeters are $4\sqrt{2}$, 6, $4 + 2\sqrt{2}$ (seven shapes), and $2 + 4\sqrt{2}$ (five shapes).

Lab 4.10: Polyrectangles

This is another generalization of the concept of polyomino, with a basic unit that is no longer a square. Another possible extension is the polyiamond (diamond, triamond, and so on), based on an equilateral triangle unit. Polyiamonds have been discussed by Martin Gardner (in his *Sixth Book of Mathematical Games from Scientific American*, chap. 18 and elsewhere).

Answers

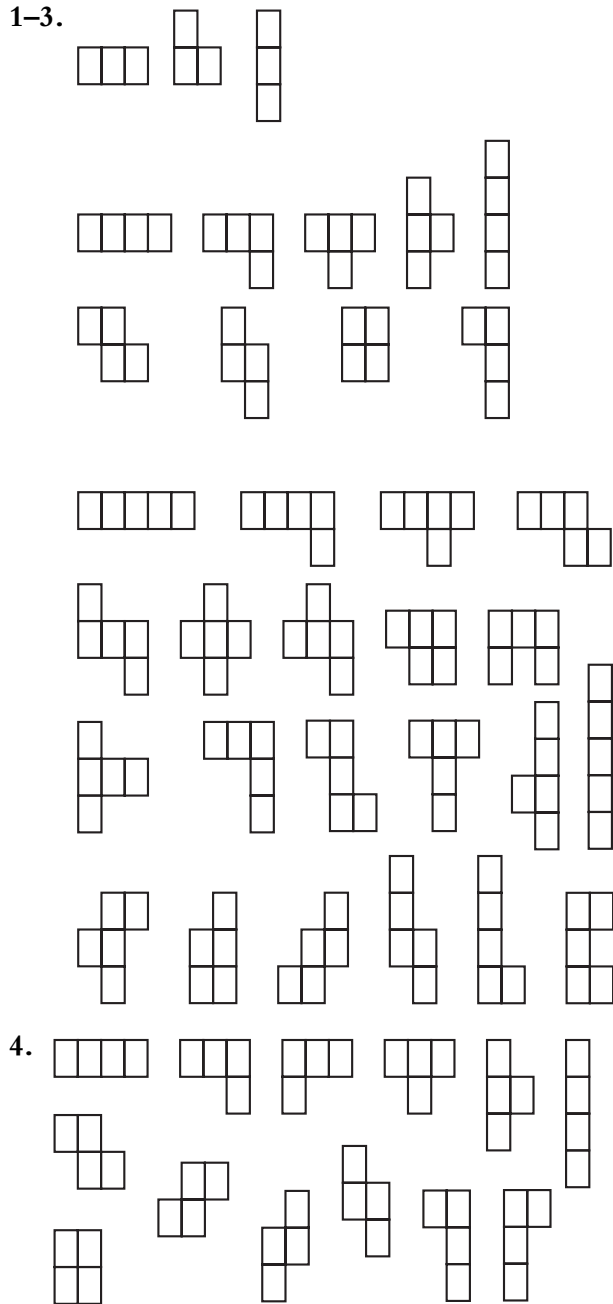

5.

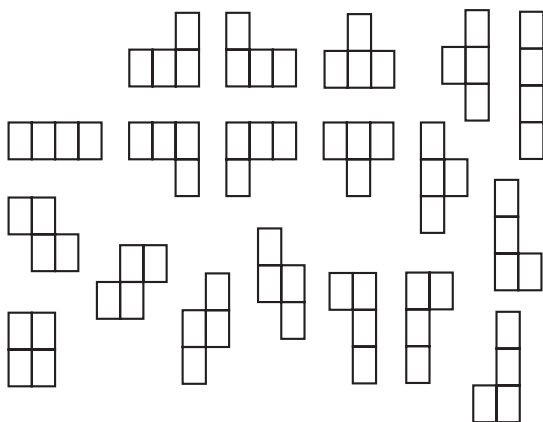

Discussion Answers

- A. Polyominoes with a diagonal line of symmetry, such as the tetromino square or the pentominoes **V**, **W**, and **X**, yield only one polyrectangle.
- B. Each polyrectangle yields one or two polystamps, depending on whether it is mirror symmetric or not. Each polystamp yields one or two one-positional polystamps.
- C. False. The less symmetrical shapes yield more versions.

5 Symmetry

Lab 5.1: Introduction to Symmetry

This is a “getting ready” activity. Understanding the meaning of line and rotation symmetry is a prerequisite to all the labs in this section.

As a way to introduce these ideas, you may lead a discussion of the activity before handing out the sheet. One way to start such a discussion is to write some student-suggested letters on the chalkboard in two categories, “special” and “not special” (corresponding to “line symmetric” and “not line symmetric”), and see whether students can guess which other letters belong in each category. Shapes other than letters can also be used, of course, and the activity can be generalized to rotation symmetry, or made more specific by requiring criteria such as a horizontal line of symmetry or more than one line of symmetry.

In Question C, students should have no trouble classifying the figures according to their rotation symmetries, but it can be difficult to explain what is meant by “ n -fold” rotation symmetry. One possible answer is that a figure has n -fold rotation symmetry if it looks exactly the same through n different turns, up to 360° . Another answer is that a figure with n -fold rotation symmetry looks unchanged when rotated by an angle of $360^\circ/n$. Point out that any figure looks the same when it’s rotated by 360° . If that’s the only rotation that doesn’t change the figure, then we say the figure does not have rotation symmetry.

Make sure your students understand that the word *fold*, in this context, is not related to folding. Students may also be misled into thinking *fold* refers to reflection symmetry only, especially since this lab mentions folding in Question B.

Note that the letters that have rotation symmetry all have half-turn symmetry. You might discuss whether X and O have rotation symmetries that other letters do not.

Bulletin board displays can be created based on the ideas in this activity, especially exhibits of discoveries made by students in working Problem 8. You may have an ongoing search, with new discoveries being added. Some students will probably enjoy looking for the longest possible answer in each. Many more examples of letter symmetries like the one in Problem 7 can be found in Scott Kim’s book *Inversions* (Key Curriculum Press), the definitive book on the subject.

For Question F, if you don’t have a dictionary in your classroom, you may ask your students to look up *symmetry* as part of their homework. *Webster’s College Dictionary* (Random House) has this first definition: “the correspondence in size, form, and arrangement of parts on opposite sides of a plane, line, or point; regularity of form or arrangement in terms of like, reciprocal, or corresponding parts.”

Answers

1. a. Answers will vary.

b.

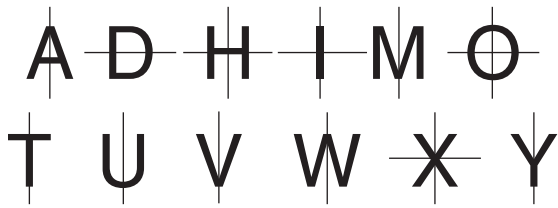

2. Line symmetric:

B, C, E, K, Q

Not line symmetric:

B, C, E, K, Q

3. Line symmetric:

c, i, l, o, v, w, x

Not line symmetric:

**a, b, d, e, f, g, h, j, k,
m, n, p, q, r, s, t, u, y, z**

4. Answers will vary.

5. Rotation symmetry:

H, I, N, O, S, X, Z

No rotation symmetry:

**A, B, C, D, E, F, G, J, K,
L, M, P, Q, R, T, U, V, W, Y**

6. Rotation symmetry:

l, o, s, x, z

No rotation symmetry:

**a, b, c, d, e, f, g, h, i, j, k,
m, n, p, q, r, t, u, v, w, y**

7. The word HORIZON is written so that it has rotation symmetry. The H becomes an N when rotated 180° and the R becomes a Z.

8. Answers will vary.

Discussion Answers

A. If a mirror is placed along the line of symmetry, the reflection of one side in the mirror matches the other side. *Bilateral* means two-sided, and line symmetric figures have two sides that are reflections of each other. Line symmetric figures, if flipped over, fit on their original outlines.

B. The two halves will cover each other exactly.

C.

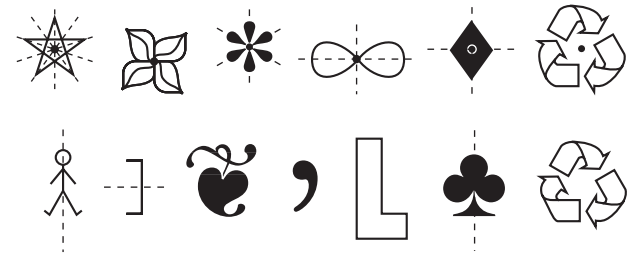

D. two-fold: infinity symbol, diamond; three-fold: recycling symbol; four-fold: pinwheel; five-fold: star; six-fold: asterisk. See Notes for explanations.

E. 180° is half of 360° , which would be a full turn. Figures with this kind of symmetry are symmetrical through their center point; that is, every point on the figure has a corresponding point the same distance from the center on the opposite side.

F. Answers will vary.

G. Among the capital letters: H, I, O, X. They all have more than one line of symmetry.

H. Answers will vary.

Lab 5.2: Triangle and Quadrilateral Symmetry

Problem 1 takes time, but it serves to consolidate students' grasp of the definitions. You may shorten it by asking for just one example of each shape, especially if your students are already familiar with the definitions.

You may lead a discussion of Question B on the overhead projector, entering appropriate

information in the relevant cells of the table for Problem 4.

Although the list of quadrilaterals may appear to be ordered in some sort of mathematical scheme, actually it is in reverse alphabetical order.

Answers

1. Answers will vary.
2. Answers will vary.
3. Answers will vary.
4. See table below.

Discussion Answers

- A. Yes. A figure with n lines of symmetry has n -fold rotation symmetry.
- B. There are figures with three- and four-fold rotation symmetry, but no lines of symmetry; however, they are not triangles or quadrilaterals. Figures with exactly one line of symmetry cannot have rotation symmetry. Figures with exactly two, three, and four lines of symmetry must have two-, three-, and four-fold rotation symmetry, respectively.
- C. Answers will vary. The scalene triangles have no symmetries. The isosceles figures have exactly one line of symmetry. If you

join the midpoints of a rhombus, you get a rectangle, and vice versa.

- D. The two lines of symmetry of the rhombus or rectangle are among the four lines of symmetry of the square. A square is a rhombus, but a rhombus is not necessarily a square. The line of symmetry of an isosceles triangle is among the three lines of symmetry of the equilateral triangle. An equilateral triangle is isosceles, but an isosceles triangle is not necessarily equilateral.

Lab 5.3: One Mirror

Prerequisites: Students should be familiar with the names of the triangles and quadrilaterals listed in the chart. In this book, those names were introduced in Lab 1.5 (Angles in a Triangle) and Lab 5.2 (Triangle and Quadrilateral Symmetry). In this activity, always use the most generic version of a figure: *isosceles* means a triangle with exactly two equal sides, *rectangle* means a rectangle that is not a square, and so on.

If you have never used mirrors with your class, you should consider giving students a little time to just play freely with them at the start of the lesson. Then, you may discuss the following examples as an introduction.

Line Symmetry	Rotation Symmetry			
	None	Two-fold	Three-fold	Four-fold
No lines	AS, RS, OS, HE, GT, GQ	PA		
One line	AI, RI, OI, KI, IT			
Two lines		RH, RE		
Three lines			EQ	
Four lines				SQ

By placing the mirror on an equilateral triangle, students can make an equilateral triangle, a kite, or a rhombus, as shown in this figure.

Equilateral → Equilateral, Kite, Rhombus

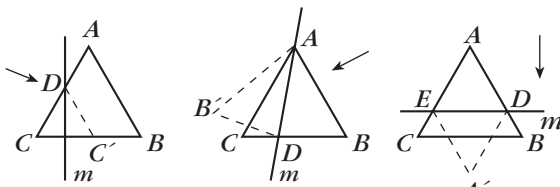

Equilateral triangle
 DCC'

Kite
 $ABDB'$

Rhombus
 $ADA'E$

(m is the mirror—the arrow indicates the side you look from)

They cannot, however, make an acute isosceles triangle, since it is impossible to get the needed non- 60° angles.

Students may work in pairs or groups to fill out the chart.

Make sure they use all the possible triangles on the template in their search for solutions. Something may be impossible with one isosceles triangle yet work with another one. (An obtuse isosceles triangle can be obtained from an acute isosceles triangle only if the vertex angle is less than 45° .) This may yield some heated discussions!

Answers

See chart below.

Figures made	By using the mirror on:							
	EQ	AI	RI	OI	AS	RS	HE	OS
Equilateral (EQ)	✓	×	×	×	×	×	✓	×
Acute isosceles (AI)	×	✓	×	×	✓	✓	×	✓
Right isosceles (RI)	×	×	✓	×	×	×	×	×
Obtuse isosceles (OI)	×	✓	×	✓	✓	✓	✓	✓
Acute scalene (AS)	×	×	×	×	×	×	×	×
Right scalene (RS)	×	×	×	×	×	×	×	×
Half-equilateral (HE)	×	×	×	×	×	×	×	×
Obtuse scalene (OS)	×	×	×	×	×	×	×	×
Quadrilaterals	EQ	AI	RI	OI	AS	RS	HE	OS
General	×	×	×	×	×	×	×	×
Kite	✓	✓	✓	✓	✓	✓	✓	✓
General trapezoid	×	×	×	×	×	×	×	×
Isosceles trapezoid	×	×	×	×	×	×	×	×
Parallelogram	×	×	×	×	×	×	×	×
Rhombus	✓	✓	✓	✓	✓	✓	✓	✓
Rectangle	×	×	×	×	×	×	×	×
Square	×	×	✓	×	×	×	×	×

Discussion Answers

- A. Pentagons and hexagons
- B. It is impossible to make any figure that is not line symmetric. This follows from the fact that any figure made with a mirror is automatically line symmetric.
- C. They are line symmetric.
- D. It is impossible to make the isosceles trapezoid and the rectangle, because the half-figure that would be needed to reflect in the mirror has two opposite parallel sides and therefore cannot be part of a triangle.
- E. The kite and rhombus can be made from any triangle, because putting a mirror on any angle will yield a kite unless the mirror is perpendicular to one side (see Question G) or perpendicular to the angle bisector. In the latter case, it makes a rhombus.
- F. Find the needed half-figure, and place the mirror along it.
- G. Place the mirror perpendicular to a side so that side yields only one side in the final figure.
- H. An acute angle in an obtuse isosceles triangle is less than 45° . If it is reflected in the mirror, its reflection will also be less than 45° . Together, they will add up to less than 90° , leaving more than 90° for the vertex angle. On the other hand, if the vertex angle in an acute isosceles triangle is less than 45° , then by the same reasoning, reflecting that angle in the mirror will create an obtuse angle for the new vertex angle, thereby making an obtuse isosceles triangle.

Lab 5.4: Two Mirrors

For this lab, students will need to attach two mirrors to each other so they form a hinge. Give the following instructions, demonstrating as you go along: Start by placing the two mirrors face to face, then tape them together along a short side. If you do this carefully, you should be able to swing them open to any angle. Unless the

angle is close to 0° or 180° , the hinged mirror pair should be able to stand up as shown here.

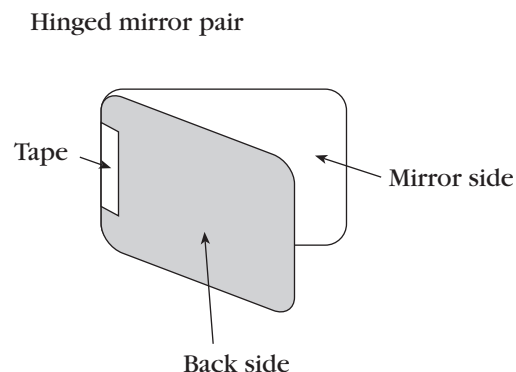

If students don't start with the mirrors face to face, the resulting contraption will not work as well. You should rule out the use of tape on the front of the mirror, as it would mar the surface.

If your students prefer to have their own mirrors to work with, rather than sharing the hinged pairs between two students, you can separate the mirrors after this lab. Otherwise, you may keep the mirrors taped together; the hinged pairs will be useful (though not necessary) in Lab 5.7 (Two Intersecting Lines of Symmetry). You can also just use the pair as a free-standing single mirror by using a very large angle (say 300°).

This lab is very rich, and potentially complex. The student page concentrates on some basic results, which Questions A–G expand to a variety of related questions. Give yourself time to explore all this on your own first, then decide how deeply you want to get into it with your class. Much of the complication stems from the fact that mirrors and theoretical lines of symmetry are not exactly the same thing: An actual mirror has a beginning and an end and reflects only in one direction, while a theoretical line of symmetry is infinite and works in both directions.

Students may use Isometric Dot Paper (see page 246) as a shortcut for getting 120° , 60° , and 30° angles.

In addition to record keeping, the template may be used to draw figures that can be reflected in the mirror pair. Drawn figures

have the advantage that the mirrors can be placed right over the figures.

Answers

1.

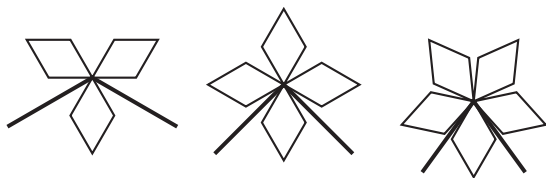

2. 120° , 90° , 72° . These are the results of dividing 360° by 3, 4, and 5.

3.



By moving the pattern block away from the mirrors and moving the mirrors closer to each other, it is possible to get seven copies of the block (including the original).

4, 5. 180° , 120° , 90° , 72° , 60° , 51.43° , 45° , 40° , 36° , 32.73° , 30°

6. One of the reflections of the mirror should be aligned with one of the mirrors (even cases); or two reflections should meet on the extension of the bisector of the angle between the two mirrors (odd cases).

7. Symmetric only: even cases
Symmetric or asymmetric: odd cases

8. Answers will vary.

Discussion Answers

A.

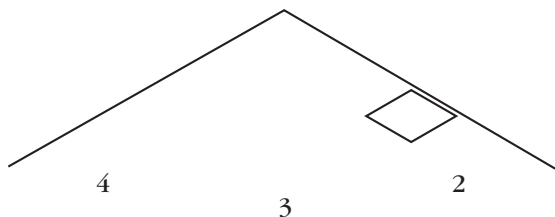

B. Mirrors: See answer to Problem 6. Objects:
See answer to Problem 7.

C. (No question)

D. 120° – 180° ; 90° – 120° ; 72° – 90°

E. The right eye of your reflection winks. This is unlike what happens in a mirror normally, because you are actually looking at the reflection of a reflection.

F. Every time you cross a mirror, you are looking at an additional level of reflection.

G. The reflection is backward, the reflection of the reflection is correct, and so on.

Lab 5.5: Rotation Symmetry

In chemistry, handedness of molecules is known as *chirality*, from the Latin root *chir-* (hand). This terminology in both languages comes from the fact that (in three dimensions) our hands are essentially identical, yet one cannot wear a left glove on a right hand. Hence the concept of handedness: It is about the difference between left- and right-handed figures.

You may also use Question G from Lab 5.4 (Two Mirrors) to discuss handedness.

You can interpret Problem 4 as a more open assignment, in which students can use any medium to create their designs. Possibilities include the following.

- any sort of geoboard
- pattern blocks
- any sort of dot or graph paper (polar graph paper works well)
- other shapes that can be found on the templates
- centimeter cubes
- tangrams
- compass and straightedge
- computer graphics programs
- geometry software
- potato prints
- rubber stamps
- anything!

If you decide to use potato prints or rubber stamps, be aware that unless the element you are reproducing is itself line symmetric you will need twin stamps that are mirror images of each

other. Students can make rubber stamps in any shape at all with the materials sold by A Small Woodworking Company, 34207 82nd Ave. S., P.O. Box 460, Roy, WA 98580, (253) 458-3370. (They also sell pattern block rubber stamps.)

You can give more structure to the assignment by specifying values for n and specific numbers of each type of figure. You can increase motivation by promising that each student's best creations will be part of a bulletin board display.

You may complement Problem 4 by asking students to search for figures with the various sorts of symmetries in magazines or anywhere in the real world. Clippings, photographs, rubbings, or sketches of what they find can be included in the bulletin board exhibit. Things to look at include hubcaps, manhole covers, logos, and so on.

1. No answer is required.
2. a. 8 b. 3 c. 4 d. 6 e. 2 f. 12
3. a, 8; f, 12
4. Answers will vary.

Discussion Answers

- A.** b, c, d, e. Figures that do not have line symmetry are the ones that have handedness.
- B.** The number n must be a positive whole number. Any figure looks the same when rotated 360° , so any figure has one-fold symmetry. However, if that is the only symmetry a figure has, it is said to be not symmetric or *asymmetric*.

Lab 5.6: Rotation and Line Symmetry

The chart lists 72 possibilities, of which there are only 24 actual solutions. However, even 24 is a large number, and you should not expect each student to find and sketch all those solutions. Finding an example of each type could be a project for each group of four students or even for a whole class, with a checklist posted on the bulletin board along with colorful drawings of student-discovered designs. You should require students to label the designs according to their

symmetry properties, and assign a couple of students to complete the exhibit by writing an explanation of rotation and line symmetry and the notation used in the table.

I have found that students are quick to find line-symmetric designs, but not so quick to find designs that have only rotation symmetry.

Answers

Answers will vary. See answer to Question A below.

Discussion Answers

- A.** Only one- and three-fold symmetries are possible for the triangle; one-, two-, three-, and six-fold symmetries are possible for the hexagon; all those, plus four- and 12-fold symmetries, are possible for the dodecagon. In each case, line symmetry is an option.
- B.** The number of sides of the figure is a multiple of n . The figure itself would not be able to be rotated by angles other than multiples of $360^\circ/n$ and come back to its position.
- C.** Answers will vary. A combination of blocks can be replaced by other combinations that cover the same space. For example, two reds can replace a yellow.
- D.** Answers will vary.
- E.** Only one- or two-fold symmetries would be possible, since those are the only symmetries of the rhombus itself.

Lab 5.7: Two Intersecting Lines of Symmetry

You may demonstrate the given example, or another one, on the overhead to show the students that there are more reflections than one might expect at first. If they did Lab 5.4 (Two Mirrors), they should be ready for that idea.

Note that the intersecting-mirrors phenomenon that constitutes the subject of this lab is the underlying feature of kaleidoscopes. (A follow-up project could be to build a kaleidoscope.)

To save time and increase accuracy, you may provide assorted graph and dot papers,

encouraging students to select carefully which sheet is most appropriate for each angle. You will find many special papers in the back of this book.

Question F does not need to be saved for last, as it contains a hint that will help speed up the process and make it more accurate: Additional lines of symmetry of the final figure can be obtained by reflecting the original ones.

Students can build on the sheets, using manipulatives of their (or your) choice. Then they can record the figure with the help of the template. Or they can use the template directly. You may hand out mirrors, hinged or not, as an aid in constructing and, especially, checking the designs. If you have Miras, those would help even more.

Of course, the list of manipulatives and other media suggested for creating rotationally symmetric designs applies to this lab as well. See the Notes to Lab 5.5 (Rotation Symmetry).

Note that Problem 3 is somewhat more difficult than Problem 2. Problems 3 and 4 could be skipped if time is short.

Answers

1. a.

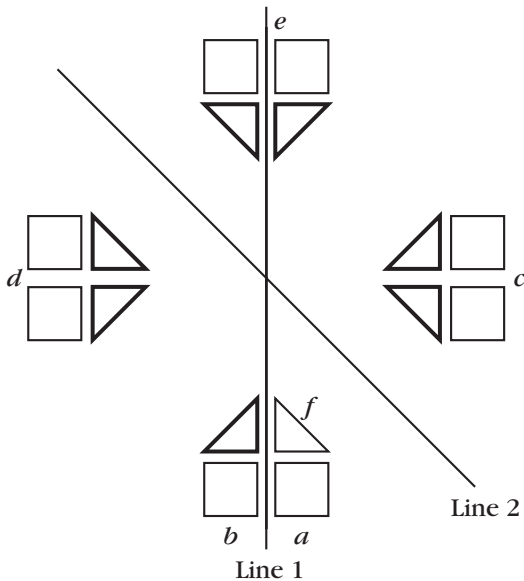

b. Answers will vary.

2. Answers will vary.

3. Answers will vary.

4. 36° and 72° . If you reflect the mirrors themselves in the 72° case, you will end up with 36° between consecutive mirrors.

Discussion Answers

A. 90° , 4; 60° , 6; 45° , 8; 30° , 12; 72° , 10; 40° , 18; 36° , 10

B. In the even cases, the figures obtained have the same symmetry. In the odd cases, the figures are always symmetric. The difference is due to the fact that lines of symmetry are infinite in both directions, while our mirrors stopped where they met. Another difference is that lines of symmetry “work” in both directions, while real mirrors only work from one side. As a result, in this lab, unlike the one that used hinged mirrors, the direction you look from is irrelevant.

C. It is possible, if the object is placed in such a way as to have its own line of symmetry match the given line and if other identical objects are placed in the corresponding places as dictated by the symmetry.

D. In the case of the drawing, it is not necessary to place it in such a way as to have its own line of symmetry match the given line. After drawing the object, you can draw its reflection across the given line.

E. They are congruent and have the same handedness. One could be obtained from the other by a rotation around the point of intersection of the two lines of symmetry.

F. It makes sense. It does not change the final result, but it does make it easier to get there.

Lab 5.8: Parallel Lines of Symmetry

This lab works very much the same way as Lab 5.7 (Two Intersecting Lines of Symmetry), which is a bit of a prerequisite.

You may demonstrate the given example, or another one, on the overhead to show the students that the reflections go on forever. To save time and increase accuracy, you may

draw the lines and duplicate them yourself. Or you can make available assorted graph and dot papers, encouraging students to select carefully which sheet is most appropriate for each angle.

Students can build on the sheets, using manipulatives of their (or your) choice. Then they can record the figure with the help of the template. Or they can use the template directly. You may hand out mirrors, hinged or not, as a help in constructing the designs. If you have Miras, those would help even more.

Of course, the list of manipulatives and other media suggested for creating rotationally symmetric designs applies to this lab as well. See the Notes to Lab 5.5 (Rotation Symmetry).

The symmetry of two parallel mirrors is often seen in designs such as the borders of rugs or architectural detail strips on buildings. If a third mirror is added at a special angle other than 90° , the symmetry becomes the symmetry of wallpaper designs, and the design expands to the whole plane.

The designs in Problems 5–7 are very difficult to generate because the pattern extends infinitely in all directions, wallpaper-style. You may want to assign those as extra credit and mount a bulletin board display of any nice creations.

Answers

- Answers will vary.
- Infinitely many
- 3–7. Answers will vary.

Discussion Answers

- Parallel mirrors, like those in a barbershop, simulate parallel lines of symmetry.
- They are congruent and have the same handedness. One could be obtained from the other by translation.
- It makes sense. It does not change the final result, but it does make it easier to get there.

- If the third mirror is perpendicular to the original two, the design stays confined to a strip in the direction of the perpendicular line. If the third mirror is not perpendicular or parallel to the first two, the design expands to cover the entire plane, like wallpaper.
- In reflecting the mirrors, one obtains parallel lines.

6 Triangles and Quadrilaterals

Lab 6.1: Noncongruent Triangles

Prerequisites: Students should know the meaning of the word *congruent*.

This lab should precede or closely follow the introduction of congruent triangles. With a full discussion, it may well take two periods.

Students may have trouble understanding these instructions if they merely read them. Make sure you demonstrate Problem 1 (or Problem 2, which is more difficult) on the chalkboard or overhead.

Problem 7 is the famous “ambiguous case” and is quite difficult. You should probably demonstrate it at the board at the end of the lab, perhaps asking all students to copy your construction. It follows from this example that the fact that two triangles have an SSA correspondence does not mean they are congruent.

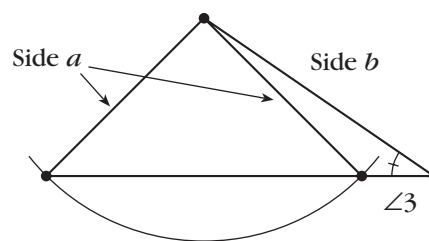

When discussing Question A, make sure students understand the difference between SAS and SSA.

Answers

- Many triangles; SA
- Many triangles; SA
- Many triangles; AA

4. No triangles; the sum of angles is greater than 180° .
5. Exactly one triangle; SSS
6. Exactly one triangle; SAS
7. Exactly two triangles; SSA
8. Exactly one triangle; ASA
9. Exactly one triangle; SAA
10. No triangles; SSSA—too many constraints

Discussion Answers

- A. See Notes and Answers above.
- B. See Notes and Answers above. SSS, SAS, and ASA are criteria for congruence of triangles. So is SAA, which is essentially a version of ASA, because once two angles are determined, the third is too.
- C. See Notes and Answers above.
- D. Problem 7

Lab 6.2: Walking Parallelograms

This is an opportunity to review the angles created when a transversal cuts two parallel lines, while getting started on the general classification of quadrilaterals. Students often are confused about “Is a square a rectangle, or is a rectangle a square?” This lesson provides one way to get some clarity on this or at least provides an additional arena for discussion. See Lab 5.2 (Triangle and Quadrilateral Symmetry) for a complementary approach.

Students could be paired up, with each member of the pair executing the instructions written by the other member. The values of the variables must be stated before starting the walk.

In Problem 5, note that a variable should NOT be used in the case of the angles of the square and rectangle, since they are always 90° .

For Problems 9 and 10, you may give the hint that there are five true statements of the type “a rhombus is a parallelogram” that apply to the four quadrilaterals discussed.

To summarize, you may explain how a tree diagram or a Venn diagram can be used to display the relationships between the four figures.

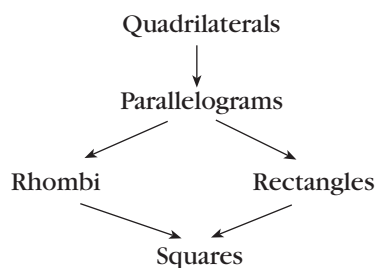
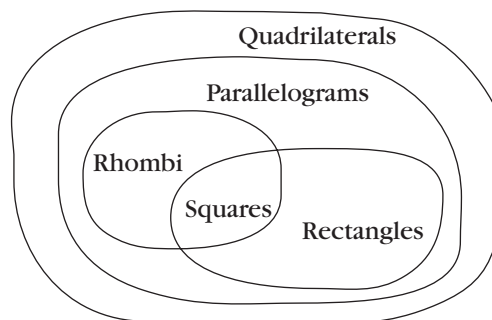

Question F is a way to follow up on a discussion about hierarchical relationships among quadrilaterals, rather than a direct extension of the lab. The answer to the question “Is a parallelogram a trapezoid?” depends on how a trapezoid is defined.

Answers

1. The first two turns add to 180° , since you’re facing opposite to your original position.
2. Turn right 40° ;
Walk forward one step;
Turn right 140° ;
Walk forward three steps;
Turn right 40° .
3. 40° and 140°
4. Do this twice:
Walk forward x steps;
Turn right a° ;
Walk forward y steps;
Turn right $(180 - a)^\circ$.

5. Answers will vary. Here are some possibilities.

a. Do this twice:

Walk forward x steps;

Turn right a° ;

Walk forward x steps;

Turn right $(180 - a)^\circ$.

b. Do this twice:

Walk forward x steps;

Turn right 90° ;

Walk forward y steps;

Turn right 90° .

c. Do this four times:

Walk forward x steps;

Turn right 90° .

6. Yes. Use the side of the rhombus for both x and y .

7. No. It would be impossible to walk a parallelogram whose sides are of different lengths.

8. a. Yes.

b. No.

9. Any square can be walked with parallelogram instructions (use equal sides and 90° angles), but not vice versa.

Any square can be walked with rhombus instructions (use 90° angles), but not vice versa.

Any square can be walked with rectangle instructions (use equal sides), but not vice versa.

Any rectangle can be walked with parallelogram instructions (use 90° angles), but not vice versa.

10. A square is a parallelogram, a rhombus, and a rectangle.

A rhombus and a rectangle are also parallelograms.

Discussion Answers

A. They are supplementary.

They are supplementary.

B. Parallelogram: three variables; rectangle and rhombus: two variables; square: one variable. The more symmetric a shape is, the fewer variables are used to define it.

C. Sides must be positive. Angles must be positive, but less than 180° .

D. Rectangle, rhombus

E. Rectangles: SS; rhombi: AS; parallelograms: SAS

F. If a trapezoid can have more than one pair of parallel sides, then parallelograms are particular cases of trapezoids. If not, there is no overlap between trapezoids and parallelograms.

Lab 6.3: Making Quadrilaterals from the Inside Out

This lab helps prepare students for the formal proofs of some quadrilateral properties. In addition to paper and pencils, you could have them use geoboards and rubber bands.

Another approach is to use (nonflexible) drinking straws or stirring sticks for the diagonals and elastic string for the quadrilateral. In the case of unequal diagonals, one of the straws can be cut. Straws can be connected with pins at the intersection. The elastic thread can be strung through holes punched near the ends of the straws or (easier but less accurate) a notch cut with scissors at the end of the straws.

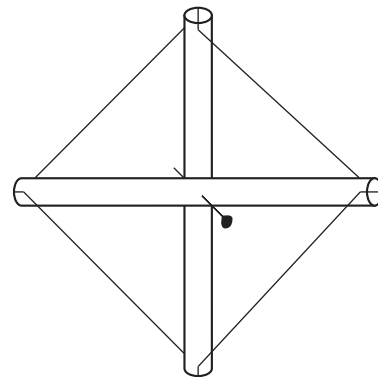

Make sure your students notice the suggestion that they try to make the most general quadrilateral that fits the given conditions. This is not easy, as students tend to be attracted to special, symmetric cases, especially when working on dot or graph paper.

For Problems 5 and 6, one student used a 3, 4, 5 triangle on dot paper (with the legs horizontal and vertical) to get a diagonal of length 5 that is not perpendicular to a horizontal or vertical diagonal of length 5 (see figure). You may suggest this method to students who are stuck.

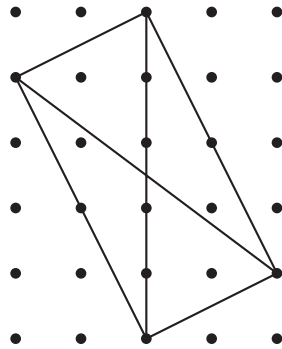

Answers

1. Square
2. General quadrilateral
3. Rhombus
4. General quadrilateral
5. Rectangle
6. General quadrilateral
7. Parallelogram
8. General quadrilateral

Discussion Answers

- A. The diagonals do not bisect each other.
- B. A kite requires perpendicular diagonals, one of which bisects the other, but not vice versa.
- C. An isosceles trapezoid requires equal diagonals that intersect each other so that the corresponding segments formed are equal.

Lab 6.4: Making Quadrilaterals from Triangles

This assignment, like the previous one, helps prepare students for the formal proofs of some quadrilateral properties. You may use it as a homework assignment.

In any case, precede it with a discussion of how to present the information. Some students have

done this in a table format, others in paragraphs, and other ideas are certainly possible. Emphasize that it is essential to clearly illustrate the report.

Problem 2 is not crucial, but it allows trapezoids to come into the activity.

Answers

1. EQ: rhombus
 AI: kite, parallelogram, rhombus
 OI: kite, parallelogram, rhombus
 AS: kite, parallelogram
 RS: kite, rectangle, parallelogram
 HE: kite, rectangle, parallelogram
 OS: kite, parallelogram
2. In addition to the quadrilaterals that can be made with two triangles, it's possible to make trapezoids, isosceles trapezoids, and right trapezoids.

Lab 6.5: Slicing a Cube

This activity is highly popular with students. The discoveries of the equilateral triangle and, especially, the regular hexagon are quite thrilling. Plan on at least two class periods to do it all. As a way to get started, students may use the template to draw various shapes on the stiff cardboard and test whether those can be cube slices.

It is possible to follow up this lab with an exhibit featuring 2- and 3-D illustrations. Here are some of the possibilities I suggested to my students (they did the work as homework).

A “movie” of the cube moving through a plane in various ways:

- face first
- edge first
- vertex first

Alternatively, the cube could be rotating around an axis and passing through a plane containing that axis. The axis could be:

- an edge
- a diagonal
- some other line

Or students could analyze:

- possible and impossible triangle slices
- possible and impossible quadrilateral slices
- possible and impossible pentagon and hexagon slices

In all cases, students should pay attention to:

- the ranges of possible side lengths
- the ranges of possible angles

Students should pay particular attention to special figures:

- the ones where a change occurs (from triangle to trapezoid, for example)
- the most symmetric ones
- the largest ones

The projects should include some text and some 2- or 3-D visual components. When completed, they can be put together in one museum-style exhibit.

Some of my students made clay models, others used the transparency cube, and others drew 2-D sketches. A couple of them chose to write explanations of why right and obtuse triangles are impossible. Two commented on the fact that some slices appear possible when drawn in two dimensions, but then turn out to be impossible to execute in three dimensions. If your students are familiar with the Pythagorean theorem and the basic trig ratios, the exhibit could have a quantitative component, with calculations of the sides of certain figures.

Answers

1, 2. No answer

3. Triangles:

- Equilateral (EQ): possible
- Acute isosceles (AI): possible
- Right isosceles (RI): impossible
- Obtuse isosceles (OI): impossible
- Acute scalene (AS): possible
- Right scalene (RS): impossible
- Half-equilateral (HE): impossible
- Obtuse scalene (OS): impossible

Quadrilaterals:

- Square (SQ): possible
- Rhombus (RH): possible
- Rectangle (RE): possible
- Parallelogram (PA): possible
- Kite (KI): impossible
- Isosceles trapezoid (IT): possible
- General trapezoid (GT): possible
- General quadrilateral (GQ): impossible

Other polygons:

- Pentagon: possible
- Regular pentagon: impossible
- Hexagon: possible
- Regular hexagon: possible
- Seven-gon: impossible

Discussion Answers

- A. See above.
- B. If the edge of the original cube is 1, the length of the sides of the slices is anywhere from 0 to $\sqrt{2}$. The angles are from 0° to 90° .
- C. An equilateral triangle, a square, and a regular hexagon are all possible. A regular pentagon is not possible, though a pentagon with one line of symmetry is possible.
- D. Yes. Start with a square slice sitting at the bottom of the cube. As you slide one side of the slice up a vertical face of the cube, the opposite side will slide along the bottom. The square will still slice the cube, but it won't be parallel to any face.

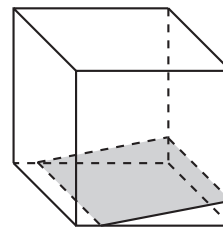

7 Tiling

Lab 7.1: Tiling with Polyominoes

Prerequisites: Students need to be familiar with the polyomino names. Since many students will have forgotten the polyomino vocabulary (which is not particularly important to remember), you

may remind them of (or supply them with a copy of) the Polyomino Names Reference Sheet (page 54).

Question B is quite difficult. One way to think about it is to break it down into two separate dimensions: First analyze the strips in the design and establish that those strips can be extended indefinitely, then judge whether the strips can be placed next to each other without holes or overlaps. Of course, some tilings may not lend themselves to this analysis. In fact, that in itself is an interesting question: Can you devise a polyomino tiling that seems to work yet does not consist of strips?

Question D applies a concept that was introduced in Lab 4.2 (Polyominoes and Symmetry).

Extension: Is it possible to tile the plane with each of the 35 hexominoes?

Answers

1. Answers will vary.

2. No.

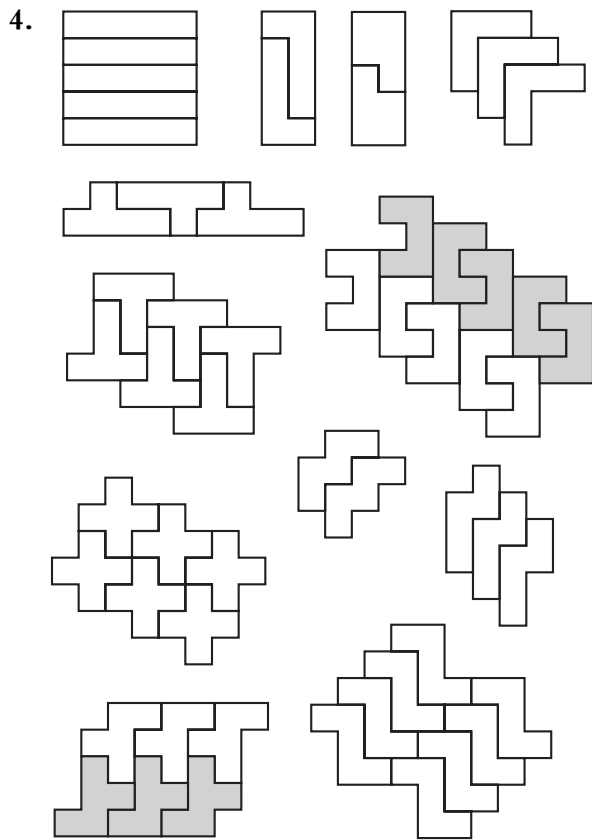
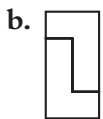
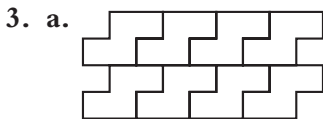
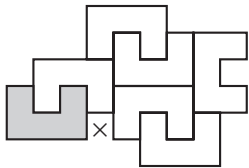

Discussion Answers

- A. Yes.
- B. See Notes above.
- C. Yes. See answers to Problems 3 and 4.
- D. Answers will vary.
- E. Answers will vary.
- F. Answers will vary.

Lab 7.2: Tiling with Pattern Blocks

This lab follows up the early pattern block labs on angles (see Lab 1.1: Angles Around a Point) and helps lay the groundwork for Lab 7.3 (Tiling with Triangles and Quadrilaterals). While this lab is not a prerequisite to Lab 7.3, it does bring students' attention to the sum of the angles around a vertex. This is the key mathematical concept here, and every student should be absolutely clear on this.

For Problem 2, make sure the students understand that they are to color the vertices, not the polygons.

Question B can lead in a couple of different directions: For example, one could avoid repetition by writing 4·090 for the vertex in a checkerboard pattern; or one could reduce the number of colors mentioned or eliminate the mention of colors altogether (although the latter approach would probably lead to ambiguous names). Another possibility is to omit the numbers in the case of the triangle, square, and hexagon, since the number is unique.

Discussions of notation are a common part of mathematics and are a legitimate secondary school activity; to avoid such discussions obscures the fact that mathematical notations are not “natural” but rather are created over time. A notation becomes standard only if enough mathematicians accept it.

Answers

- Answers will vary.
- The first kind of vertex is where only triangles meet. The other one is any other vertex.

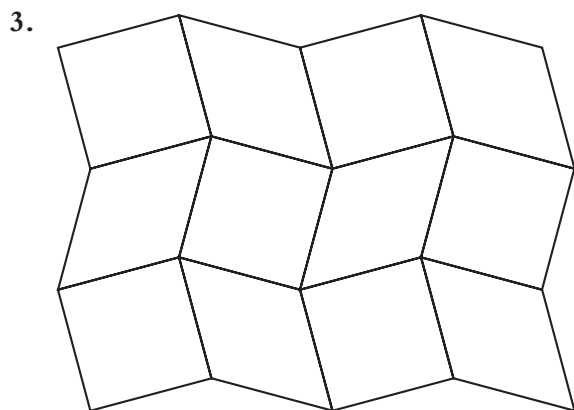

- Answers will vary.

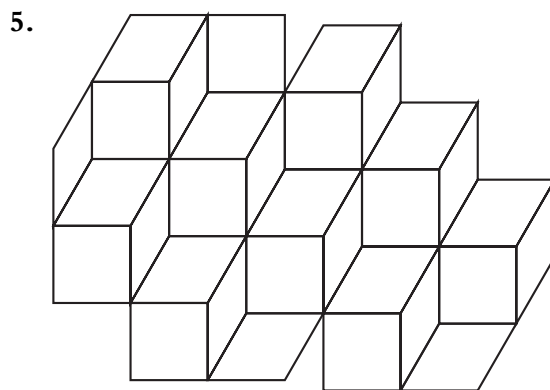

- Answers will vary.
- The angles do not add up to 360° .

Discussion Answers

- They must add up to 360° . An arrangement of pattern blocks around a vertex can be the start of a tiling pattern.
- See Notes above.
- Answers will vary.

Lab 7.3: Tiling with Triangles and Quadrilaterals

In Problem 1, do not expect each student to discover all 16 tilings alone—it would be time-consuming and repetitive. Groups of two to four students can work on it, and the final results can be colored and displayed on the bulletin board. If you are short on time, only ask for a scalene triangle and general quadrilateral tilings. If students come up with shortcuts based on observations like the ones in Question B, that will speed up the process as well as develop their visual experiences with triangles and quadrilaterals.

Students may have trouble with some cases, however, particularly the asymmetrical ones that are addressed in Problems 2–4. If so, you may give some or all of the following hints.

- Match like sides.
- Make strips, then juxtapose them.
- It is not necessary to flip the figures over.
- All the angles around a vertex must add up to 360° . How can this be accomplished given

what you know about the angles of a triangle?
About the angles of a quadrilateral?

The final point is probably the key.

One technique that facilitates exploration is to take a sheet of paper, fold it in half three times, then draw a triangle or quadrilateral on it. If you cut it out, you get eight identical copies, and that's usually enough to conduct experiments. Be careful, though, that you don't turn over any of the triangles or quadrilaterals. To avoid that problem, make sure all the copies are placed on the table with the same face up, and mark or color that face.

The explanations in Problems 2 and 4 are not easy to write and may take you beyond one class period. You may ask students to write only one of the two. In any case, encourage your students to discuss their approaches with each other and perhaps with you and to write drafts before embarking on the final version. Hopefully, the points listed in the hints above will appear in the students' write-ups. Remind them that well-labeled illustrations are a must in a report of this sort.

Answers

- Answers will vary.
- No. Possible explanation: Any two copies of a triangle can be arranged to make a parallelogram. The parallelograms can be arranged to make strips.
- Answers will vary.
- Copies of the quadrilaterals must be arranged so that matching sides are adjacent and all four angles are represented at each vertex. An example is shown here.

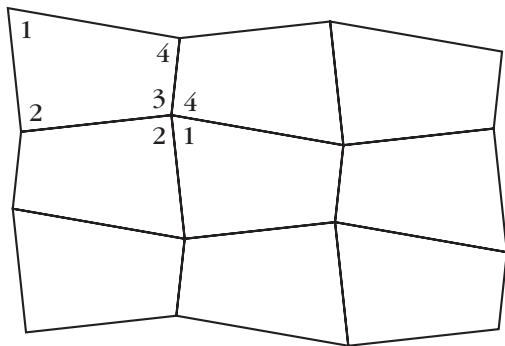

Discussion Answers

- Answers will vary.
- Answers will vary.
- Answers will vary.

Lab 7.4: Tiling with Regular Polygons

Problem 1 revisits work students may have already done in Lab 7.2 (Tiling with Pattern Blocks). In fact, for some of the regular polygons, it is convenient to use the pattern blocks. For others, see the Note in Lab 7.3 (Tiling with Triangles and Quadrilaterals) about cutting out eight copies of the tiles in order to experiment.

If students are stuck on Problem 2, you may suggest as a hint that they read the text following Problem 3.

Problem 4 is yet another take on the “angles around a point” concept. See Labs 1.1 (Angles Around a Point), 7.2, and 7.3. Note that an arrangement of regular polygons around a point is a necessary but not sufficient condition for a tiling.

In Question C, eight of the eleven tilings can be made with pattern blocks, and all can be made with the template.

If some students are particularly interested in these questions, you could ask about the possibility of tiling with regular polygons that are not on the template. It is not too difficult to dismiss 9- and 11-gons by numerical arguments based on their angles.

Answers

- Equilateral triangle, square, regular hexagon
- Their angles are not factors of 360° .
- Answers will vary.
- There are twelve ways to do this, including three one-polygon solutions, six two-polygon solutions, and three three-polygon solutions:
 - 6 triangles
 - 4 squares
 - 3 hexagons

- 2 hexagons, 2 triangles
- 1 hexagon, 4 triangles
- 2 octagons, 1 square
- 2 dodecagons, 1 triangle
- 2 squares, 3 triangles
- 1 decagon, 2 pentagons
- 1 hexagon, 2 squares, 1 triangle
- 1 dodecagon, 1 hexagon, 1 square
- 1 dodecagon, 1 square, 2 triangles

5. Answers will vary.
6. Answers will vary. Example: If you start a tiling by surrounding a vertex with two pentagons and a decagon, you find that a third pentagon is necessary next to the first two. On the other side of the pentagons, you are forced to use two decagons, but those must overlap each other, which ruins the tiling.

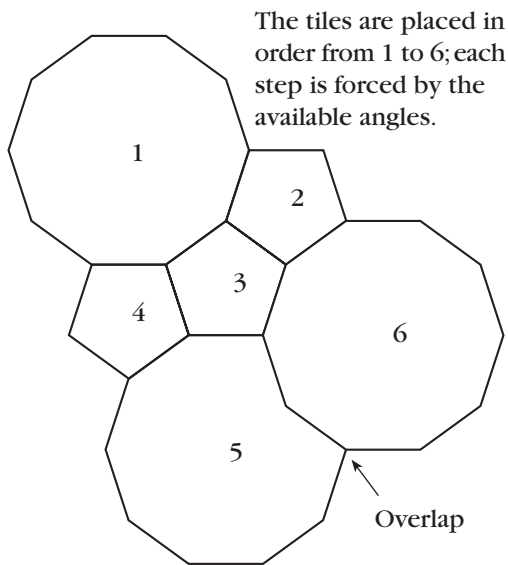

Discussion Answers

- A. This can be done with equilateral triangles; squares; and hexagons with triangles.
- B. 15-gon: triangle, decagon
 18-gon: triangle, nonagon (9-gon)
 20-gon: square, pentagon
 24-gon: triangle, octagon
 42-gon: triangle, heptagon

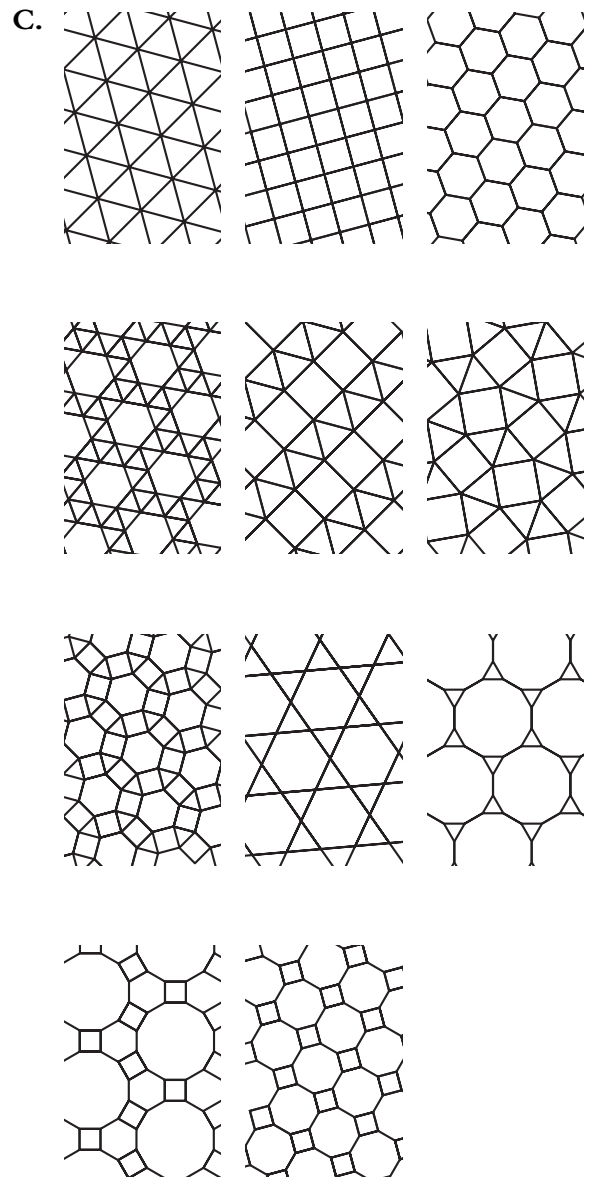

- D. Answers will vary. Most tilings will have parallel and nonparallel lines of symmetry. Nonparallel lines will form 30° , 45° , 60° , or 90° angles. Centers of rotation symmetry will be found at centers of polygons, at midpoints of edges, and at vertices. They may have the same or different n -fold symmetries: two-fold, three-fold, four-fold, or six-fold.

8 Perimeter and Area

Lab 8.1: Polyomino Perimeter and Area

This lab is highly recommended, as it is usually guaranteed to generate intense involvement.

Prerequisites: It is not necessary to have done the labs in Section 4 (Polyominoes) in order to do this lab. The definition of polyominoes given here is equivalent to the one from Section 4 and is more relevant to this section.

Timing: This can easily be a two-day investigation, especially if you take the time to have students make the graph as suggested in Question C, then discuss the three-way relationship between the figures, the numbers in the table, and the graph.

Problems 1 and 2 remind students of the meaning of perimeter and area and establish the basic questions of the investigation. Filling out the table can seem overwhelming, but a pattern quickly emerges for the longest perimeters. The shortest perimeters are more difficult to understand, but they usually generate a great deal of curiosity (see below). The prediction exercises are the students' opportunity to articulate the patterns they discovered while making the table.

After some false starts, students usually discover that the shortest perimeters increase by 2 in the following manner: one 4, one 6; two 8s, two 10s; three 12s, three 14s; and so on. On the graph, this shows up as a staircase whose steps get longer at every other step. More patterns will be discussed in the following lab.

One way to answer Question D is to use the graph. For example, to figure out whether there is a polyomino with both area and perimeter equal to 14, one can plot the point (14, 14) and observe whether it is in the feasible area (the area that lies between the two graphs). The line $P = A$ can be graphed on the same axes, which will make it clear that there are polyominoes with equal area and perimeter for all even numbers greater than or equal to 16.

Answers

1. H: area 7, perimeter 16
P: area 7, perimeter 12
2. Answers will vary.

3.

Area	Minimum perimeter	Maximum perimeter
1	4	4
2	6	6
3	8	8
4	8	10
5	10	12
6	10	14
7	12	16
8	12	18
9	12	20
10	14	22
11	14	24
12	14	26
13	16	28
14	16	30
15	16	32
16	16	34
17	18	36
18	18	38
19	18	40
20	18	42
21	20	44
22	20	46
23	20	48
24	20	50
25	20	52
26	22	54

4. $P_{\max} = 2A + 2$
5. Answers will vary. See Labs 8.2 and 8.3.
6. a. 49 min. $\frac{28}{\quad}$ max. $\frac{100}{\quad}$
 b. 45 min. $\frac{28}{\quad}$ max. $\frac{92}{\quad}$
 c. 50 min. $\frac{30}{\quad}$ max. $\frac{102}{\quad}$
 d. 56 min. $\frac{30}{\quad}$ max. $\frac{114}{\quad}$

Discussion Answers

- A. No. Every unit of length in the perimeter is matched by another unit on the opposite side, so the total must be even.
- B. Answers will vary.
- C. The maximum perimeter is a linear function of the area. The minimum is a step function, with the steps getting longer and longer. See graph on next page.
- D. The smallest such polyomino is a 4×4 square, with area and perimeter equal to 16. All even areas greater than 16 can be arranged to have a perimeter equal to the area. See Notes.
- E. Answers will vary. See Lab 8.2.

Lab 8.2: Minimizing Perimeter

Prerequisite: Lab 8.1 (Polyomino Perimeter and Area) is a prerequisite, since this lab attempts to develop a geometric insight into the toughest part of that lab, the minimum perimeter for a given area.

Finding a formula for the minimum perimeter is too difficult for most students, but the insights generated in this lesson can lead to the following algorithm.

- Find out whether A is a square number, that is, $A = n^2$ for some n , or a rectangular number, that is, $A = n(n + 1)$ for some n . If so, the minimum perimeter is $4n$ in the first case and $4n + 2$ in the second case.
- If A is not a square number, then the minimum perimeter is the same as that for the next higher number that is a square or rectangular number.

Actually, there is a formula for the minimum perimeter. It is

$$P = 2\lceil 2\sqrt{A} \rceil,$$

where $\lceil \quad \rceil$ represents the ceiling function. The ceiling of a number is the least integer greater than or equal to the number. For example:

$$\lceil 2 \rceil = 2$$

$$\lceil 2.1 \rceil = 3$$

$$\lceil 2.8 \rceil = 3$$

Explanation: It is easy to see that, in the case of area A as a perfect square, the formula for the minimum perimeter can be written $P = 4\sqrt{A}$, since \sqrt{A} gives you the side of the square. In the case of an area less than a perfect square but greater than the immediately preceding rectangular number, the formula becomes $P = \lceil 4\sqrt{A} \rceil$. The difficulty comes in the case of areas equal to or immediately less than a rectangular number. A little experimentation will show you that, in this case, the formula given above works in all cases. The proof is based on the above insights, themselves a consequence of the spiral argument suggested at the end of the lab. It is presented here for your benefit, as it is unlikely to be meaningful to your students.

Proof: There are two cases, as described above.

First case: If $(n - 1)n < A \leq n^2$, where n is a natural number, then $P = 4n$. By distributing, the compound inequality can be rewritten: $n^2 - n < A \leq n^2$. But since we are only talking about whole numbers, it is still true (via completing the square) that $n^2 - n + \frac{1}{4} < A \leq n^2$, and therefore

$$\left(n - \frac{1}{2}\right)^2 < A \leq n^2 \quad \text{Factor.}$$

$$n - \frac{1}{2} < \sqrt{A} \leq n \quad \text{Square root.}$$

$$2n - 1 < 2\sqrt{A} \leq 2n \quad \text{Multiply by 2.}$$

(Proof continues on page 211.)

8.1 C

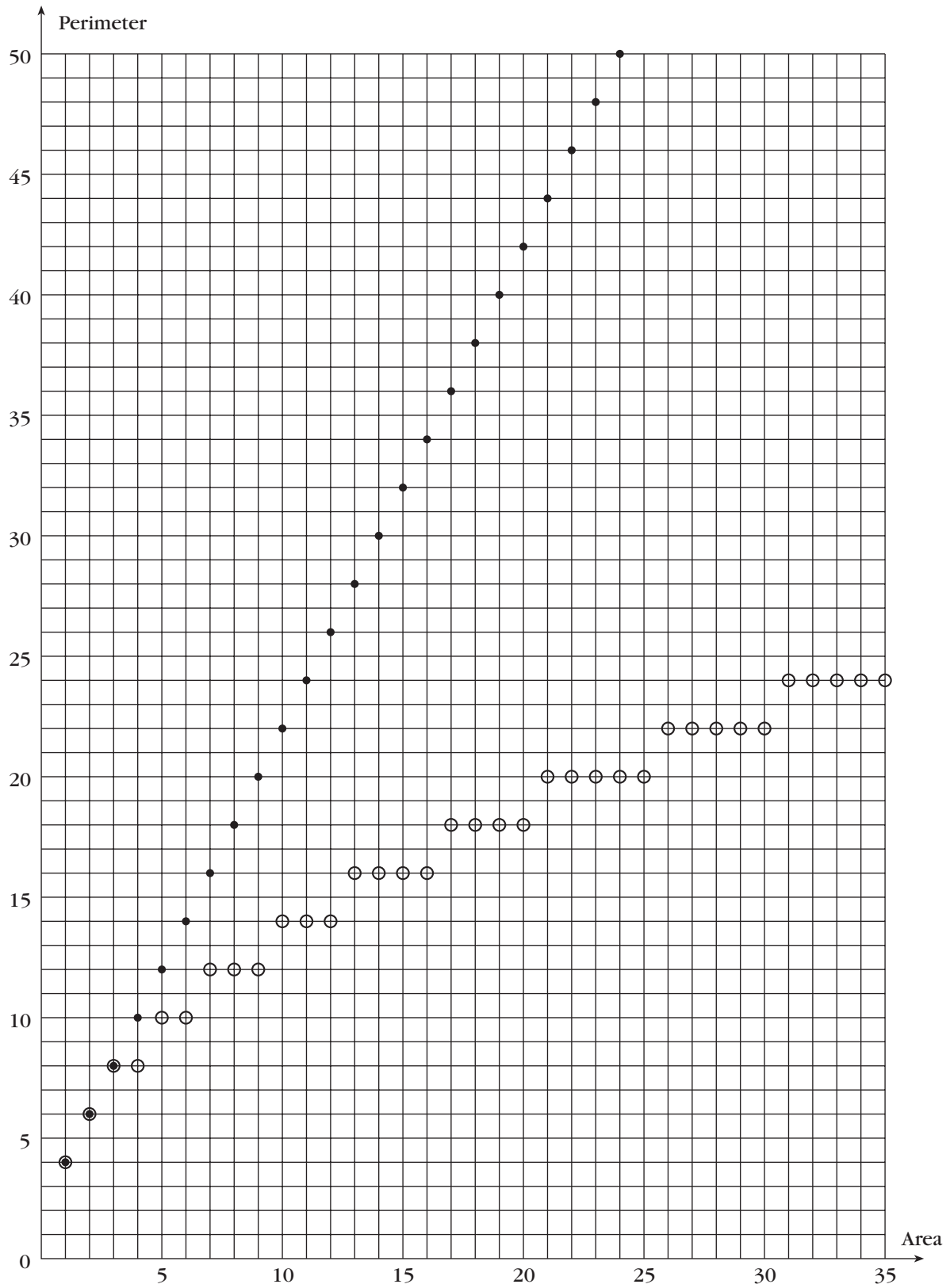

This shows that $\lceil 2\sqrt{A} \rceil = 2n$, and since $P = 4n$, the equation for minimum perimeter is $P = 2\lceil 2\sqrt{A} \rceil$.

Second case: If $n^2 < A \leq n(n + 1)$, then $P = 4n + 2$. A similar argument to the previous one leads to the inequality

$$2n < 2\sqrt{A} \leq 2n + 1.$$

In this case, $\lceil 2\sqrt{A} \rceil = 2n + 1$, and since $P = 4n + 2$, once again the equation for minimum perimeter is $P = 2\lceil 2\sqrt{A} \rceil$.

Answers

- They alternate between two types of special numbers: perfect squares and the products of consecutive whole numbers.
- 1, 4, 9, 16, 25
- 2, 6, 12, 20
- a. 120
b. 122
c. 120
- $29 \cdot 30 = 870$, $30 \cdot 31 = 930$
- a. 122
b. 124
c. 118
- The perimeter increases by 2 whenever a unit square is added to a perfect square or rectangle.

Discussion Answers

- A, B.** Squares (and rectangles that are nearly square) are compact and minimize perimeter. In building the spiral, adding a square usually covers two side units from the old perimeter and adds two new side units, which is why the perimeter does not increase. However, when you add a piece to a square or rectangle, you are adding 3 and subtracting 1, so the net effect is to increase the perimeter by 2.
- C.** a. $4n$
b. $4n + 2$

Lab 8.3: A Formula for Polyomino Perimeter

The formula relating area to perimeter and inside dots is a particular case of Pick's formula, which will be explored in its full generality in Lab 8.6 (Pick's Formula).

The puzzle in Problem 7 is not closely related to the rest of the page, but it can be useful in keeping your fastest students occupied while their classmates continue to work on the previous questions.

The wording of Question D is slightly misleading in that there actually is no greatest area for a given number of inside dots, since one can append an inside-dotless tail of any length to a figure.

Questions C and D suggest the related questions: What is the greatest number of inside dots for a given area? What is the least area for a given number of inside dots? These questions are difficult because they are related to the problem of the minimum perimeter for a given area.

Answers

1.

Perimeter	Area	Inside dots
12	9	4
14	9	3
18	11	3

- Answers will vary.
- You are subtracting 2 from the perimeter.
- Answers will vary.
- You are adding 2 to the perimeter.
- $P = 2A - 2i + 2$

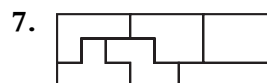

Discussion Answers

- A.** It is the same.
B. The first one has fewer inside dots.
C. 0

- D. There is no greatest area. See Notes for this lab.
- E. There are $(n - 1)^2$ inside dots.
- F. There are $n(n - 1)$ inside dots.

Lab 8.4: Geoboard Area

This lab sets the foundation for later work, especially in Section 9 (Distance and Square Root).

The opening problem is deliberately open-ended. It provides a friendly entry into the subject: Students will find their own level, as there are not only plenty of easy solutions, but also many very tricky ones. If students seem stuck on rectangles, praise and share more eccentric discoveries. A discussion of student creations on the overhead can serve as a foundation for the whole lab. You may also consider going back to Problem 1 to seek additional solutions after doing the rest of the lab.

The best approach for Problem 2 is to build a rectangle around the triangle and divide its area by 2.

Students often have difficulty thinking of the subtraction method that is necessary for Problems 4 and 5. It may be useful to discuss an example or two on the overhead. This technique will be important later on, so make sure all the students understand it.

On the other hand, the last two problems are not essential. Problem 6 is an opportunity to discuss the shearing of triangles, which can be useful in thinking about complicated geoboard areas. Problem 7 is an opportunity to practice what was learned in this lab.

Answers

- Answers will vary.
- 1.5; 3
- 6; 6; 4.5
- 2.5
- 4; 5; 6

6. Base 8, height 2: seven triangles
Base 4, height 4: nine triangles
Base 2, height 8: ten triangles
(including one that is congruent to a base-8, height-2 triangle)

So there is a total of 25 noncongruent triangles with an area of 8.

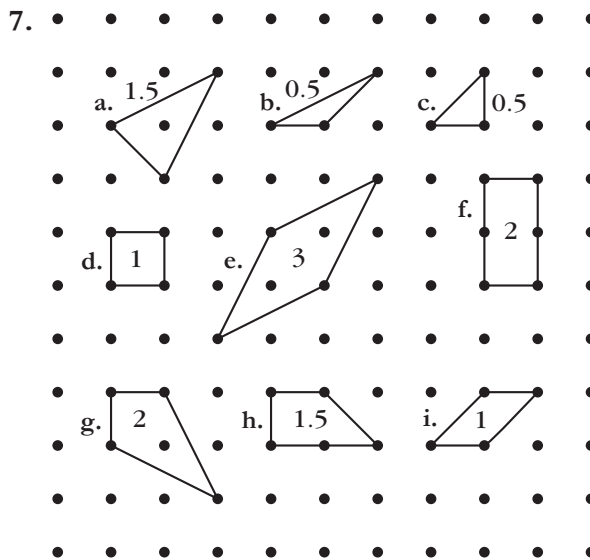

Discussion Answers

- A. The mistake results from counting the pegs rather than finding the lengths of the sides.
- B. Answers will vary but should include the following ideas.
- Division by 2: “Easy” right triangles are half of a rectangle.
 - Addition: Complicated figures can sometimes be broken up into smaller ones.
 - Subtraction: Complicated figures can be surrounded by a large rectangle or square.
- C. The area remains constant, and equal to half the product of base and height.
- D. Answers will vary.

Lab 8.5: Geoboard Squares

Prerequisites: In order to find the areas of the squares, students should have done Lab 8.4 (Geoboard Area), where the necessary techniques are introduced.

Timing: Even though the main part of the lab has only one question, it will take more than one period. It's worth it, because this is a crucially important lab that develops students' visual sense, prepares them for the work on distance in Section 9, and leads to a proof of the Pythagorean theorem.

At first, students only find the horizontal-vertical squares. Then they usually discover the squares that are tilted at a 45° angle. As soon as someone finds another square past the first 15, I usually hold it up for everyone to see, as a hint about how to proceed.

For many students, it is extraordinarily difficult to actually find the tilted squares. One approach, which helps answer Questions A and B, is to make an "easy" square, say, 5×5 . Then the vertices of another square can be obtained by moving clockwise from each vertex a given number of units. The resulting figure is perfectly set up for finding the area.

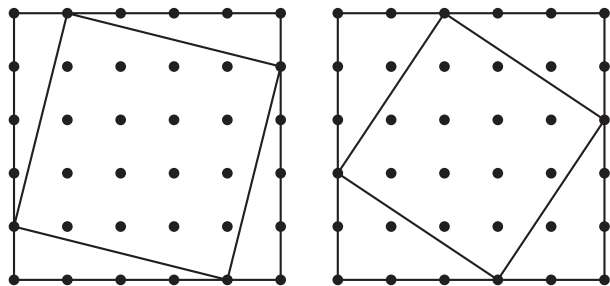

Students may find what appear to be 35 different squares, but once they calculate the areas they will see that there are duplicates.

If your students are not yet comfortable with the concept of square root, this lab is a perfect opportunity to talk about it. The horizontal-vertical squares provide an easy way to start the discussion: The side of a square of area 49 is 7,

or $\sqrt{49}$. In the case of the tilted squares, if the area is 5, then the side must be $\sqrt{5}$.

Make sure students save the results of their work, as it will be useful when working on Lab 9.1 (Taxicab Versus Euclidean Distance).

Note that Question D outlines a standard proof of the Pythagorean theorem. If your students have studied congruent triangles, the proof can be made rigorous by first proving that the initial shape is indeed a square. The fact that they will have drawn the figures and done these calculations repeatedly when working on Problem 1 will make the proof accessible to many more students.

Answers

1. Areas: 1, 2, 4, 5, 8, 9, 10, 13, 16, 17, 18, 20, 25, 26, 29, 32, 34, 36, 37, 40, 41, 45, 49, 50, 52, 53, 58, 64, 65, 68, 81, 82, 100. Sides: the square roots of the areas.

Discussion Answers

- A. Measure with the corner of a piece of paper. Alternatively, count pegs up and across for a given side, and check that by rotating the board 90° you still have the same counts for the other sides.
- B. One method is to start with each of the "easy" squares, using the method outlined in the Notes to this lab to find all the squares that are nested within it.
- C. Yes, there are squares with area 25 in two different orientations and squares with area 50 in two different orientations.
- D.
 - a. $a + b$
 - b. $(a + b)^2$
 - c. $\frac{ab}{2}$
 - d. $(a + b)^2 - 4\left(\frac{ab}{2}\right) = a^2 + b^2$
 - e. $\sqrt{a^2 + b^2}$

Lab 8.6: Pick's Formula

Prerequisites: Lab 8.4 (Geoboard Area) provides the necessary foundation. This lab is also related to Lab 8.3 (A Formula for Polyomino Perimeter), although that is a prerequisite only for Question C.

Pick's formula is a surprising result, and the search for it is a worthwhile mathematical challenge at this level. There is no need for students to memorize it, but if they do, they may find it useful when working on Lab 9.1 (Taxicab Versus Euclidean Distance).

Answers

1. 4.5

2.

Inside dots	Boundary dots	Area
3	5	4.5
4	4	5
2	12	7

3. Answers will vary.

4. The area increases by 1.

5. Answers will vary.

6. The area increases by $\frac{1}{2}$.

7. $A = i + \frac{b}{2} - 1$

Discussion Answers

A. There is no limit to the area for a given number of inside dots, because a tail of any length can be added to the figure without adding any more inside dots.

B. $A = \frac{b}{2} - 1$

C. It is essentially the same formula, though it is more general. The perimeter of a polyomino is equal to its number of boundary dots.

9 Distance and Square Root

Lab 9.1: Taxicab Versus Euclidean Distance

Prerequisites: Lab 8.5 (Geoboard Squares) is essential, both for its introductory work with square roots and for laying the visual and computational groundwork for the calculation of Euclidean distance.

The purpose of Problem 1 is to clarify something that Euclidean distance is not and also to help frame students' thinking about Euclidean distance, since in both cases it is useful to use horizontal and vertical distance (run and rise, as we say in another context). If you think students need to work more examples, those are easy enough to make up. In fact, you may ask students to make up some examples for each other.

For Problem 2, students can use either their records from Lab 8.5 or Pick's formula to find the area of the squares, or the Pythagorean theorem if they think of it and know how to use it.

Problem 3 is an interesting but optional extension. For a discussion of a taxicab geometry problem related to Problem 3, see Lab 9.6 (Taxicab Geometry).

Question A requires the use of absolute value. If your students are not familiar with it, you may use this opportunity to introduce the concept and notation, or you may skip this problem.

The answer to Question C is a consequence of the triangle inequality (in Euclidean geometry).

We return to taxi-circles in Lab 9.6.

Answers

1. a. 11
b. 10
c. 4
d. 6.4
e. 3.24
f. 5.64
2. a. $\sqrt{65}$
b. $\sqrt{29}$
c. 2.5
d. 5
e. 0.9

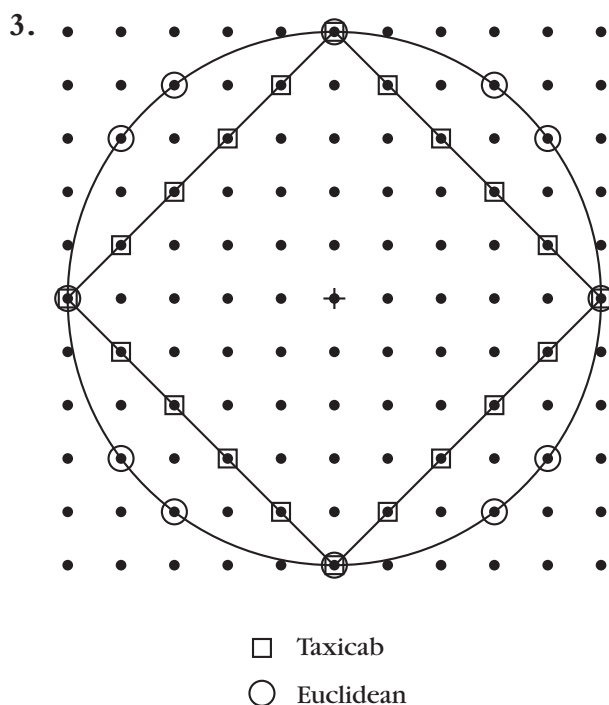

Discussion Answers

- A. $T(P_1, P_2) = |x_1 - x_2| + |y_1 - y_2|$
- B. Yes. We have equality if B is inside the horizontal-vertical rectangle for which A and C are opposite vertices.
- C. Taxicab distance is greater if the two points are not on the same horizontal or vertical line. If they are, taxicab and Euclidean distances are equal.

D. Because a circle is a set of points at a given distance from a center

Lab 9.2: The Pythagorean Theorem

Prerequisites: This lab wraps up a series that started with Lab 8.4 (Geoboard Area). The most important labs in the series are 8.4, 8.5, and 9.1.

Dot paper will work better than geoboards, because the figures are difficult to fit in an 11×11 board. However, there is no reason to prevent students who want to work on the geoboards from doing that.

Of course, the experiment in Problem 2 does not constitute a proof of the Pythagorean theorem. In Lab 8.5, Question D outlines the key steps of such a proof. Still, it's important to go through this activity because many students memorize the Pythagorean theorem (which is certainly among the most important results in secondary math) with little or no understanding. This lab, particularly if it is followed by Question A, helps make the theorem more meaningful.

You may ask students to memorize the formula $a^2 + b^2 = c^2$ or, perhaps, the less traditional but more explicit $\text{leg}_1^2 + \text{leg}_2^2 = \text{hyp}^2$.

If you don't have time for it, it is not necessary to get a complete list as the answer to Question C; a few examples are enough. If your students are interested in getting a full listing, it will be easy to obtain after doing Lab 9.4 (Distance from the Origin).

Answers

1.

Area of squares		
Small	Medium	Large
5	20	25

2. Answers will vary.
3. Area of small square
+ area of medium square =
area of large square

4. In a right triangle, the sum of the areas of the squares on the legs equals the area of the square on the hypotenuse.

5. a. $\sqrt{61}$
b. $\sqrt{50}$ or $5\sqrt{2}$
c. 4
d. 4.664 . . .
e. 3.24
f. 4.032 . . .

6. a. 12
b. 12
c. 12
d. 16
e. 16

Discussion Answers

- A.** Answers will vary. The Pythagorean theorem will fail. In the case of acute triangles, the large square is less than the sum of the other two. In the case of obtuse triangles, it is greater.
- B.** In the case of horizontal distance, it is enough to take the absolute value of the difference between the x -coordinates. In the case of vertical distance, it is enough to take the absolute value of the difference between the y -coordinates.
- C.** The following is a list of the vertices other than $(0, 0)$. More can be found by switching the x - and y -coordinates.

Legs of length 5:

$(5, 0)$ $(4, 3)$

$(5, 0)$ $(3, 4)$

Legs of length 10: double the above coordinates.

Legs of length $\sqrt{50}$:

$(5, 5)$ $(7, 1)$

Legs of length $\sqrt{65}$:

$(8, 1)$ $(7, 4)$

$(8, 1)$ $(4, 7)$

Legs of length $\sqrt{85}$:

$(9, 2)$ $(7, 6)$

$(9, 2)$ $(6, 7)$

Lab 9.3: Simplifying Radicals

Prerequisites: Once again, Lab 8.5 (Geoboard Squares) is required.

Simple radical form is no longer as important as it used to be as an aid to computation, since it is actually no simpler to enter $7\sqrt{3}$ into your calculator than $\sqrt{147}$. Conceptually, however, this technique remains important, as it is impossible to fully understand square roots and radicals without understanding this method. Moreover, simple radical form is often useful in problem solving and in communication, as it makes it easier to recognize certain common square roots. The geometric approach presented in this lab helps anchor the technique in a visual image. This does not make the actual manipulation easier to do, but it does help students to see it in a different way, it makes it easier to retain for some students, and it gives everyone a deeper understanding. Availability of technology is not an excuse for teaching less—it is an opportunity to teach more.

Answers

1. a. 10

b. $\sqrt{10}$

c. 40

d. See Problem 2.

2. The side of the large square can be thought of as $\sqrt{40}$ or as twice the side of the small square: $2\sqrt{10}$.

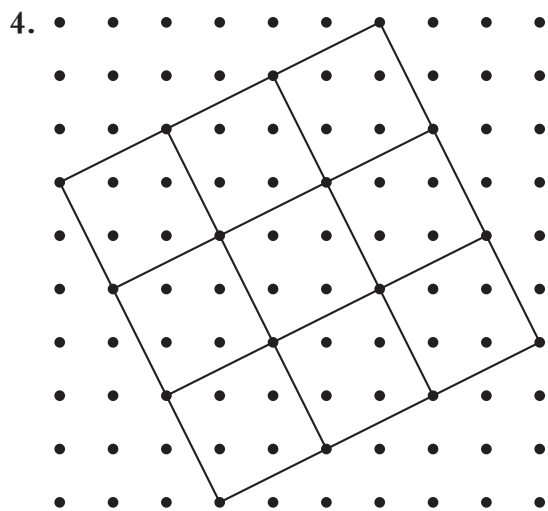
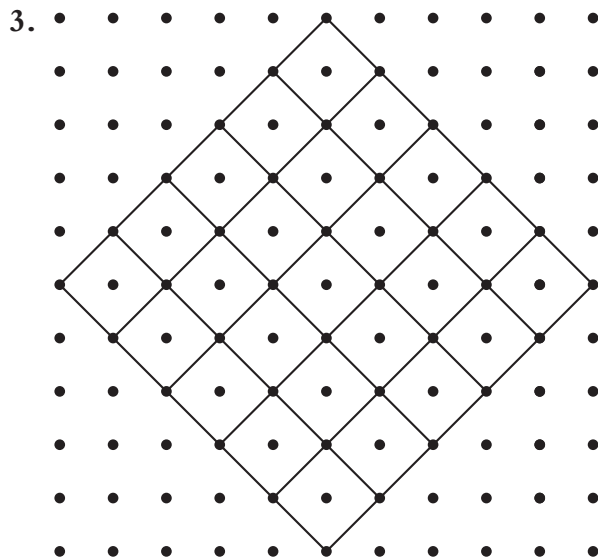

5. a. $3\sqrt{2}$
 b. $3\sqrt{5}$
 c. $2\sqrt{6}$
 d. $4\sqrt{2}$
 e. $5\sqrt{3}$
 f. $7\sqrt{2}$

Discussion Answers

A.

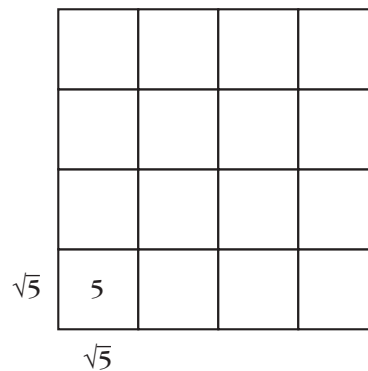

The side of the large square is $4\sqrt{5}$. Its area is $5 \cdot 16 = 80$. It follows that $4\sqrt{5} = \sqrt{80}$.

B. If the square of m is the greatest square that is a factor of n , we have $n = km^2$ for some number k . It follows that a square of area n could be divided into m^2 squares of area k . So $\sqrt{n} = m\sqrt{k}$. (Here, n , m , and k are positive whole numbers.)

Lab 9.4: Distance from the Origin

Prerequisites: Familiarity with the Pythagorean theorem, simple radical form, and slope. This lab makes connections among all these concepts and works well as a wrap-up report on the work done in Labs 8.5, 9.1, 9.3, and 9.4.

Students may use the records of their work from Lab 8.5 (Geoboard Squares), but don't suggest it if they don't think of it. Instead, encourage them simply to apply the Pythagorean theorem many times. This provides a useful, nonrandom drill. Working with neighbors and looking for patterns should speed up the process.

Answers

1.

10	10	$\sqrt{101}$	$2\sqrt{26}$	$\sqrt{109}$	$2\sqrt{29}$	$5\sqrt{5}$	$2\sqrt{34}$	$\sqrt{149}$	$2\sqrt{41}$	$\sqrt{181}$	$10\sqrt{2}$
9	9	$\sqrt{82}$	$\sqrt{85}$	$3\sqrt{10}$	$\sqrt{97}$	$\sqrt{106}$	$3\sqrt{13}$	$\sqrt{130}$	$\sqrt{145}$	$9\sqrt{2}$	$\sqrt{181}$
8	8	$\sqrt{65}$	$2\sqrt{17}$	$\sqrt{73}$	$4\sqrt{5}$	$\sqrt{89}$	10	$\sqrt{113}$	$8\sqrt{2}$	$\sqrt{145}$	$2\sqrt{41}$
7	7	$5\sqrt{2}$	$\sqrt{53}$	$\sqrt{58}$	$\sqrt{65}$	$\sqrt{74}$	$\sqrt{85}$	$7\sqrt{2}$	$\sqrt{113}$	$\sqrt{130}$	$\sqrt{149}$
6	6	$\sqrt{37}$	$2\sqrt{10}$	$3\sqrt{5}$	$2\sqrt{13}$	$\sqrt{61}$	$6\sqrt{2}$	$\sqrt{85}$	10	$3\sqrt{13}$	$2\sqrt{34}$
5	5	$\sqrt{26}$	$\sqrt{29}$	$\sqrt{34}$	$\sqrt{41}$	$5\sqrt{2}$	$\sqrt{61}$	$\sqrt{74}$	$\sqrt{89}$	$\sqrt{106}$	$5\sqrt{5}$
4	4	$\sqrt{17}$	$2\sqrt{5}$	5	$4\sqrt{2}$	$\sqrt{41}$	$2\sqrt{13}$	$\sqrt{65}$	$4\sqrt{5}$	$\sqrt{97}$	$2\sqrt{29}$
3	3	$\sqrt{10}$	$\sqrt{13}$	$3\sqrt{2}$	5	$\sqrt{34}$	$3\sqrt{5}$	$\sqrt{58}$	$\sqrt{73}$	$3\sqrt{10}$	$\sqrt{109}$
2	2	$\sqrt{5}$	$2\sqrt{2}$	$\sqrt{13}$	$2\sqrt{5}$	$\sqrt{29}$	$2\sqrt{10}$	$\sqrt{53}$	$2\sqrt{17}$	$\sqrt{85}$	$2\sqrt{26}$
1	1	$\sqrt{2}$	$\sqrt{5}$	$\sqrt{10}$	$\sqrt{17}$	$\sqrt{26}$	$\sqrt{37}$	$5\sqrt{2}$	$\sqrt{65}$	$\sqrt{82}$	$\sqrt{101}$
0	0	1	2	3	4	5	6	7	8	9	10
	0	1	2	3	4	5	6	7	8	9	10

Discussion Answer

A. Answers will vary.

- The distances are symmetric with respect to the $y = x$ line.
- Multiples of a given distance all lie on two lines with reciprocal slopes. For example, the multiples of $\sqrt{5}$ are on the lines with slope $1/2$ and 2 , respectively.

Lab 9.5: Area Problems and Puzzles

Prerequisites: In this lesson, students apply the formula for the area of a triangle (area = base · height/2) as well as for the Pythagorean theorem to some “famous right triangles”: the isosceles right triangle, the half-equilateral triangle, and the less illustrious $1, 2, \sqrt{5}$ triangle. We will return to all of these from a variety of viewpoints in the next three sections.

Timing: This is not really a lab. It’s a collection of problems, puzzles, and projects that can be used flexibly as enrichment.

Problem 1 reviews inscribed and central angles. See Lab 1.8 (The Intercepted Arc).

Problem 4 is a giant hint toward solving Problem 5.

Problem 6 is challenging. There are several stages in solving it: First, students need to figure out the side of the required square ($\sqrt{5}$); then they need to figure out how to use what they know about this to help them make the cuts; finally, they can try to improve their solution by minimizing the number of cuts. This last phase is optional, and students should certainly be considered successful if they find any solution.

The X can be done in just two cuts (and four pieces), as shown by this figure.

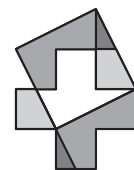

One way to find this solution is to superimpose two tilings of the plane: one tiling with the X, and one tiling with squares of area 5. The areas created by the overlapping figures form the dissection.

If your students enjoy Problem 6, a similar puzzle is to dissect a pentomino and rearrange the pieces to form two squares. The same approach used in Problem 6 works, as shown here.

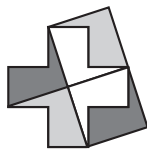

These puzzles are called dissections and are a part of ancient mathematics and recreational mathematics. A surprising result is that any polygon can be squared, that is, cut into pieces that can be reassembled into a square. Your students may try their hands at doing this with other polyominoes. A famous problem from antiquity is the squaring of the circle, which was later proved to be impossible.

Problem 7 is a substantial project. Students who take it on should be encouraged to follow the strategy outlined in Lab 8.6 (Pick's Formula): keeping one variable constant and changing the other to see how it affects the area.

Answers

1.

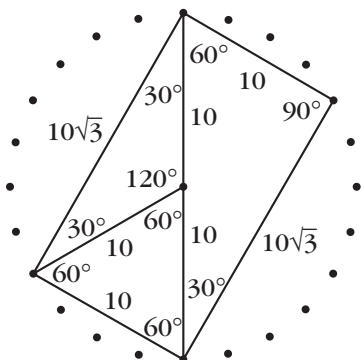

2.

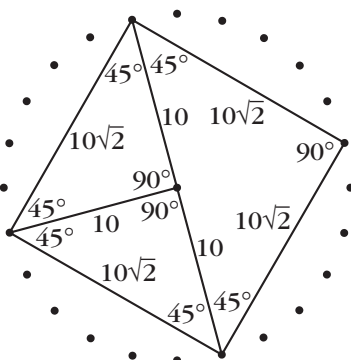

3. a. $50\sqrt{3}$, $25\sqrt{3}$, $25\sqrt{3}$
 b. 100, 50, 50

4. Two tan blocks, one green
 Or: one orange, one green
 5. Orange: 1

Green: $\frac{\sqrt{3}}{4}$

Yellow: $\frac{3\sqrt{3}}{2}$

Blue: $\frac{\sqrt{3}}{2}$

Red: $\frac{3\sqrt{3}}{4}$

Tan: $\frac{1}{2}$

6. See Notes to this lab.
 7. Rectangular array: If the rectangles are $1 \times k$, the formula is $A = k(i + b/2 - 1)$.

Triangular array: $A = \frac{\sqrt{3}}{4}(2i + b - 2)$

There is no equivalent for Pick's theorem on a hexagonal lattice. You can see this in the counterexample given on the figure: It shows two triangles that have the same area and the same number of boundary dots but a different number of inside dots. If there were a version of Pick's theorem on a hexagonal lattice, it would require that the number of inside dots be the same in the two triangles.

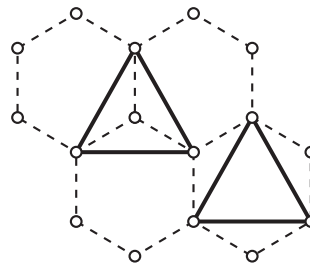

Lab 9.6: Taxicab Geometry

Prerequisites: Taxicab distance is introduced in Lab 9.1 (Taxicab Versus Euclidean Distance).

Timing: This is not really a lab, but a collection of problems that are suitable for in-class exploration or special student projects. To do it all would certainly take more than one period. If you want to do less than the full lesson, limit yourself to Problems 1–3 and Problems 6–8.

Geoboards are likely to be too small for this lesson.

Problem 1 should help students get into the taxicab world. A full discussion of it would have to include Question A.

Problem 2 is pivotal. Understanding the reason for the different cases is really fundamental to the remaining problems on the page.

The Euclidean concepts echoed in these problems are the *perpendicular bisector* (Problem 2), the *triangle inequality* (Problem 3 and Question B), the *ellipse* (Problem 4), and the *construction* of various circles (Problems 7–9). The Euclidean version of Problem 5 is more difficult. See “A New Look at Circles,” by Dan Bennett, in *Mathematics Teacher* (February 1989).

For more problems in this domain, including taxi-parabolas, see *Taxicab Geometry*, by Eugene F. Krause (Dover, 1987).

Answers

1. Answers will vary. Samples include the following.
 - a. $(0, 0)$ $(3, 1)$ $(1, 3)$. Taxicab sides are 4, 4, 4. Euclidean sides are $\sqrt{10}$, $\sqrt{10}$, $2\sqrt{2}$.
 - b. $(0, 0)$ $(5, 1)$ $(2, 4)$. Taxicab sides are 6, 6, 6. Euclidean sides are $\sqrt{26}$, $3\sqrt{2}$, $2\sqrt{5}$.

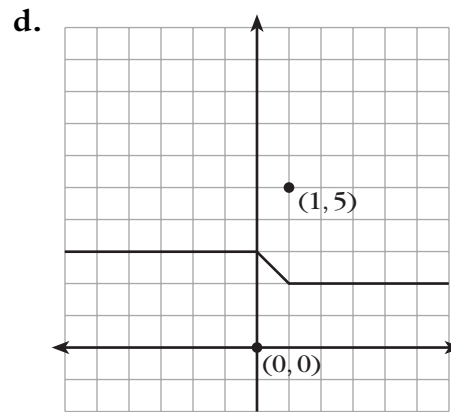
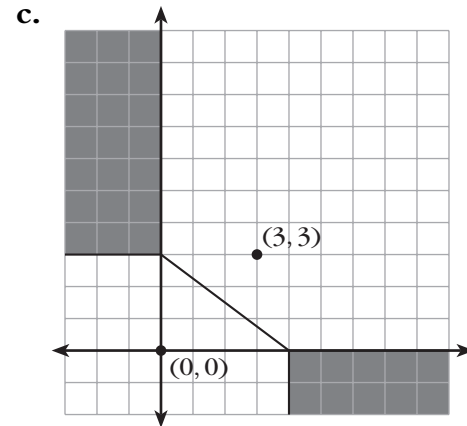
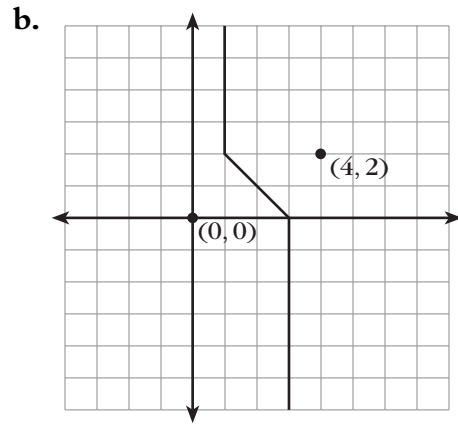
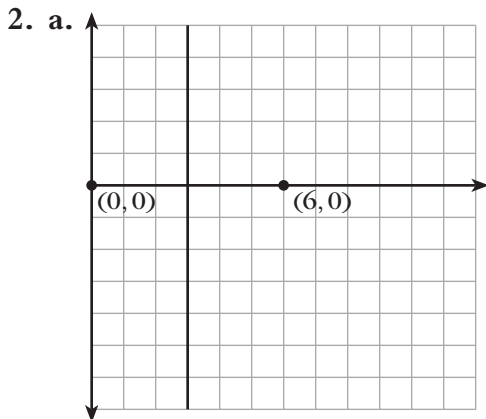

3. For Problem 3a, it is the line segment joining the points. For the other cases, it is the filled rectangle having the two points as opposite vertices.

4. a.

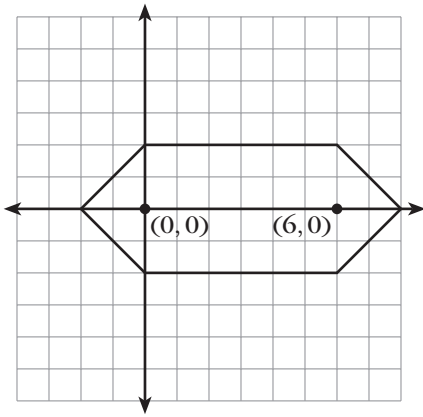

b.

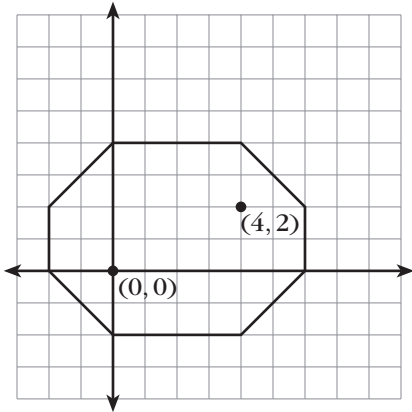

c.

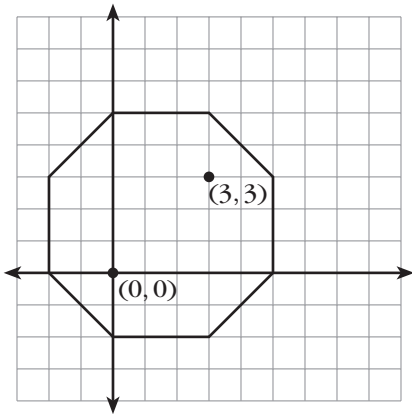

d.

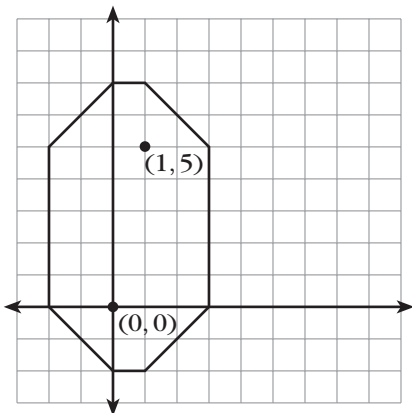

5. a.

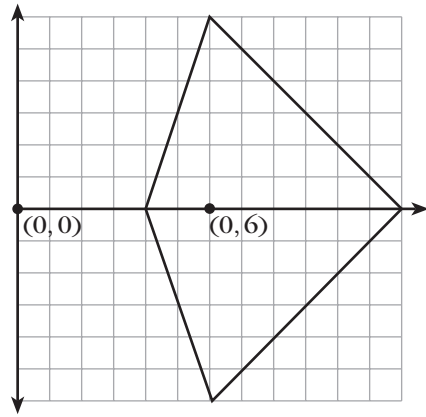

b.

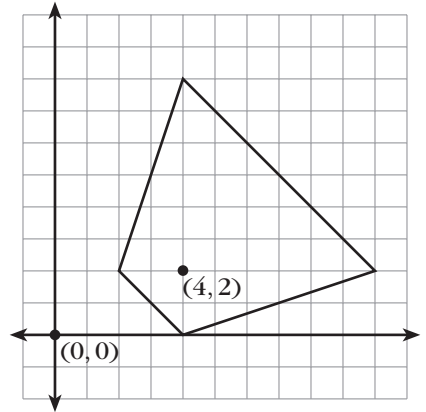

c.

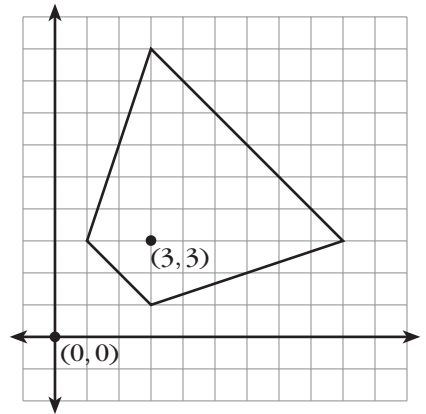

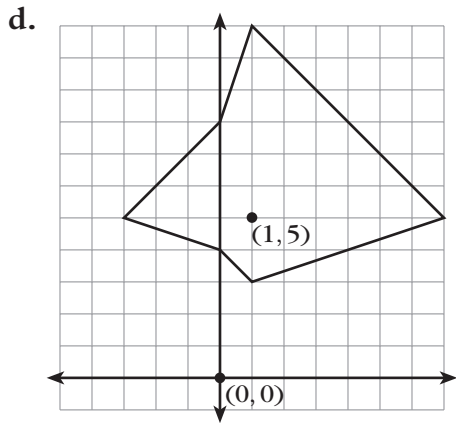

6. Taxi- $\pi = 4$
7. The centers are at $(4, 3)$ and $(5, 6)$.
8. The center can be at any point that is equidistant from A and B . (See Problem 2.) To actually draw the circle, find its radius first (the taxi-distance to A or B).
9. To explore this question, you need to explore different combinations of the cases from Problem 2. If the intersection of the sets of equidistant points is a single point, then that point is the center of the only suitable circle. However, in some cases the intersections can consist of no points (hence no center and no circle) or an infinite number of points (hence an infinite number of circles).

Discussion Answers

- A. If $PA = PB$, then P can be any point on the sets you sketched in Problem 2. If $PA = AB$, then you can draw a taxi-circle centered at A with radius AB . Then P can be any point on that circle.
- B. For two points, the set of points is the filled horizontal-vertical rectangle with the two points at opposite vertices.

10 Similarity and Scaling

Lab 10.1: Scaling on the Geoboard

Prerequisites: Students should be familiar with the concept of slope for Problems 4 and 5.

This lab introduces the concept of similarity and scaling and previews the theorems about the midpoints of triangles and quadrilaterals. It also provides a review of slope and distance.

The problem of constructing a segment whose midpoint is on a peg is interesting, and you may want to discuss it as a prelude (or postscript) to Problems 4 and 5, perhaps using the overhead geoboard to structure the conversation. One way to think about it is to note that the coordinates of the midpoint are the average of the coordinates of the endpoints. Therefore, if the midpoint is on a peg, the sum of the x -coordinates of the endpoints must be even, since it is twice the x -coordinate of the midpoint. But if the sum is even, then the difference must be even also; thus, the run is even. An analogous argument applies to the y -coordinates and the rise. The answer to Question C follows from these observations.

In Problem 5, students discover that the quadrilateral obtained by joining the midpoints of the sides an arbitrary quadrilateral is a parallelogram. While this fact, by itself, is not about similarity, it is included in this lab because its proof follows from the result discovered in Problem 4. See answers to Problems 4 and 5 and Question D.

Answers

1. To obtain (b) from (a), double the horizontal dimensions, or double the x -coordinates.
To obtain (c) from (a), double the vertical dimensions, or double the y -coordinates.
To obtain (d) from (a), double both the horizontal and vertical dimensions, or double both the x - and y -coordinates.
2. a. Copy (d) is scaled.
b. Copy (b) is too wide; copy (c) is too tall.
3. The scaling factor for (a) to (d) is 2.
The scaling factor for (d) to (a) is $1/2$.
4. Answers will vary.
 - a. The segment connecting two midpoints should be parallel to the other side and half as long. The small triangles should be

congruent to each other and similar to the original triangle.

- b. The scaling factor is 2 or $1/2$. Other answers will vary.
5. Answers will vary.
- a. The quadrilateral obtained by joining the midpoints of the sides of the original quadrilateral should be a parallelogram.
 - b. Answers will vary.

Discussion Answers

- A. See answer to Problem 1.
- B. They are reciprocals of each other.
- C. It is impossible. One way to explain this is that if the midpoint of \overline{AB} is on a peg, the rise and run from A to B are even, and likewise for \overline{BC} . The total rise and run for \overline{AC} is obtained by adding the directed rises and runs of \overline{AB} and \overline{BC} and therefore must also be even. This forces the midpoint to be on a peg.
- D. See answers to Problems 4 and 5. If you draw a diagonal of the quadrilateral, it is divided into two triangles. Using the result of Problem 4 on those triangles, you have two opposite sides of the inner quadrilateral that are both parallel to the diagonal and half as long. This is enough to guarantee a parallelogram.

Lab 10.2: Similar Rectangles

Prerequisites: The concept of slope is essential to Problems 3b and c and 5.

Timing: Problems 4 and 5 can be time-consuming, but they are well worth it.

This lab concentrates on similar rectangles. It has been my experience that (pedagogically) this is a more fundamental concept than the similar triangles we traditionally start with. Note that the lab provides an opportunity to review equivalent fractions, and their decimal representation, in a context that is new for many students.

At the same time, the lab reviews and reinforces the concept of slope, emphasizing the geometry of it rather than the concept of rate of change (which would, of course, be the core idea in an algebra, precalculus, or calculus course). Question D in particular provides an opportunity to discuss symmetry questions related to slope: Symmetry across the $y = x$ line corresponds to reciprocal slopes, and symmetry across the x - or y -axis corresponds to slopes opposite in sign. A detour is possible here to discuss the geometry of negative reciprocal slopes; they belong to perpendicular lines. This is a standard algebra 2 or precalculus topic that the geoboard makes accessible in earlier courses. This property is usually proved with the help of the Pythagorean theorem, but a perhaps more elegant way to get at the result is to observe that taking the negative of the reciprocal amounts to two reflections across lines that make a 45° angle to each other. This yields a 90° rotation. The lab also helps prepare students for the next section, where the idea of the trigonometric tangent is founded on the concept of slope.

Answers

1. The angles are equal in both cases. The ratios of the sides are equal in (a): $2/3 = 4/6$, but they are not in (b): $2/3 \neq 5/6$.
2. The diagonal does not go through the vertex of the smaller rectangle.
3. a. (1, 2) (2, 4) (3, 6) (4, 8) (5, 10)
(2, 1) (4, 2) (6, 3) (8, 4) (10, 5)
b. 2
c. $\frac{1}{2}$
4. In addition to the set listed in 3a, we have the following:
(1, 1) (2, 2) (3, 3) (4, 4) (5, 5) (6, 6) (7, 7) (8, 8) (9, 9) (10, 10)
(1, 3) (2, 6) (3, 9) (3, 1) (6, 2) (9, 3)
(1, 4) (2, 8) (4, 1) (8, 2)
(1, 5) (2, 10) (5, 1) (10, 2)
(2, 3) (4, 6) (6, 9) (3, 2) (6, 4) (9, 6)
(2, 5) (4, 10) (5, 2) (10, 4)

(3, 4) (6, 8) (4, 3) (8, 6)
 (3, 5) (6, 10) (5, 3) (10, 6)
 (4, 5) (8, 10) (5, 4) (10, 8)

5. Geoboard slopes between 1 and 2, inclusive, are: 1 ; $1.\overline{1} = 10/9$; $1.125 = 9/8$;
 $1.\overline{142857} = 8/7$; $1.\overline{16} = 7/6$; $1.2 = 6/5$;
 $1.25 = 5/4$; $1.\overline{285714} = 9/7$; $1.\overline{3} = 4/3$;
 $1.4 = 7/5$; $1.\overline{428571} = 10/7$; $1.5 = 3/2$;
 $1.6 = 8/5$; $1.\overline{6} = 5/3$; $1.75 = 7/4$;
 $1.8 = 9/5$; 2 .

Discussion Answers

- A.** If rectangles are similar (and in the same orientation—vertical or horizontal), then the slopes of the diagonals should be the same. If the rectangles are nested so that they share a vertex, then the diagonals through that vertex should coincide.
- B.** If the point (a, b) is part of the answer, then so is (b, a) .
- C.** It is easier to find the slopes as fractions (“rise over run”), but decimal notation makes it easier to compare the slopes with each other.
- D. a.** Use the reciprocals.
b. Use the opposites.
c. Use the reciprocals of the opposites.

Lab 10.3: Polyomino Blowups

Prerequisites: Students should know the definition of similar figures; Lab 10.1 (Scaling on the Geoboard) previews some of the ideas in this lesson.

Timing: Problems 7 and 8 could take a long time. They are engaging for many students, but they are not necessary to the lesson. A good compromise would be to use Problems 8b and 8c as extra-credit, out-of-class assignments.

Another approach to this lesson is to start with Problems 7 and/or 8, in order to create the motivation for Problems 1–6. Make sure students have a copy of the Polyomino Names Reference Sheet, from Section 4 (page 54), since it is unlikely that they will still remember the names of the various pieces.

Some students may prefer working all the problems on grid paper, without the cubes. That is quite all right.

For puzzle fiends among your students, here are some added challenges.

- The doubled tetrominoes can be tiled with only **I**'s.
- The doubled pentominoes can be tiled with mostly **P**'s (only three **N**'s are needed).
- The tripled pentominoes can be tiled with exactly five **P**'s and four **L**'s each.
- The tiling of quadrupled tetrominoes and pentominoes could be explored.

Not every tripled tetromino can be tiled with the same number of **I**'s and **t**'s. This can be proved by a checkerboard argument. Color the tripled tetrominoes like a checkerboard. Note that the **I** will always cover an even number of black squares, and the **t** will always cover an odd number of black squares. In the tripled square, **I**, **i**, and **n**, there are eighteen black squares, so there's a need for an even number of **t**'s in the final figure. However, in the tripled **t**, there is an odd number of black squares (seventeen or nineteen), so there's a need for an odd number of **t**'s in the final figure.

Answers

1. Copy (d) is similar to the original because the measurements have been doubled in both dimensions, which means that the sides are proportional.

2. (In the Perimeter table, numbers in the Horiz. and Vertic. columns could be switched, depending on the orientation of the original polyomino.)

	Perimeter				Area			
	Original	Doubled			Original	Doubled		
		Horiz.	Vertic.	Both		Horiz.	Vertic.	Both
Monomino	4	6	6	8	1	2	2	4
Domino	6	10	8	12	2	4	4	8
Bent	8	12	12	16	3	6	6	12
Straight	8	14	10	16	3	6	6	12
Square	8	12	12	16	4	8	8	16
l	10	14	16	20	4	8	8	16
i	10	12	18	20	4	8	8	16
n	10	14	16	20	4	8	8	16
t	10	16	14	20	4	8	8	16

3. Answers will vary.
 4. When measurements are doubled in both dimensions, the perimeter is doubled and the area is multiplied by four.
 5. Predictions will vary.
 6. Perimeter is multiplied by 3 or 4. Area is multiplied by 9 or 16.

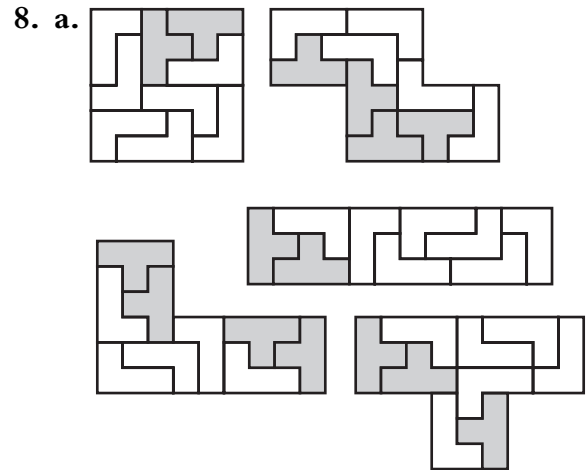
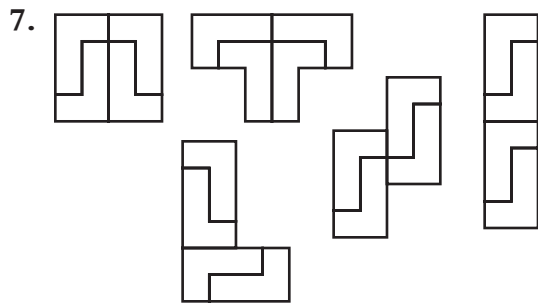

b.

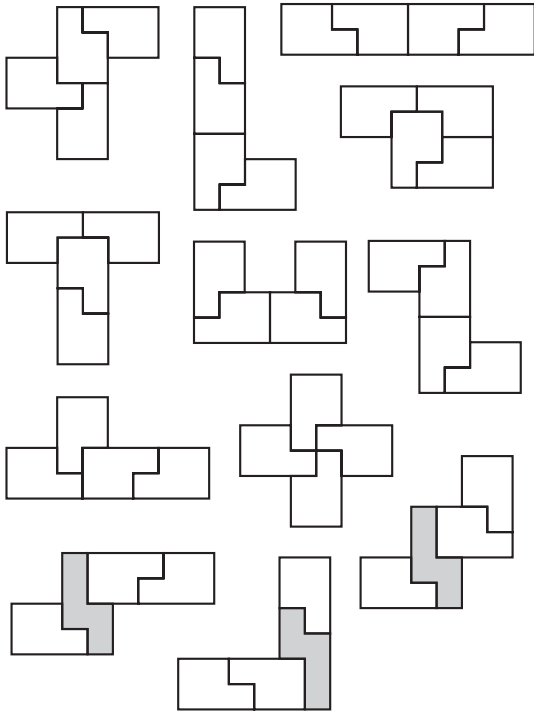

c.

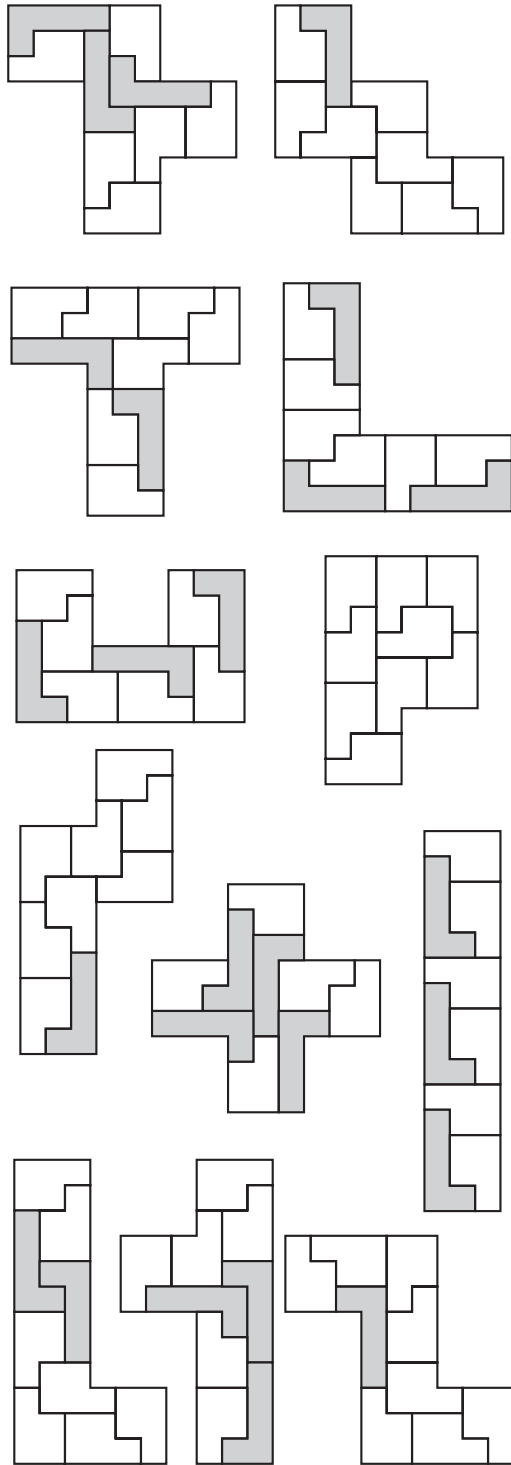

Discussion Answers

- A.** They are the same.
- B.** The ratio of areas is the square of the scaling factor. This is because the area is multiplied by the scaling factor twice, once for each dimension.
- C.** Nine. Because tripling a polyomino multiplies its area by $3^2 = 9$.
- D.** Tiling would require k^2 polyominoes, because multiplying the dimensions by k will multiply the area by k twice, once for each dimension.

Lab 10.4: Rep-Tiles

Prerequisites: Students should know the definition of similar figures; it would be helpful to have done some of the previous labs in this section.

This lab provides further practice with similarity and the ratio of areas in the context of now familiar shapes.

For Problems 1–3, students may prefer to work with pencil and eraser on grid paper rather than using the interlocking cubes.

Problem 3 is time-consuming and you may consider skipping it, since its conclusion is disappointing. It is challenging to make arguments about the impossibility of certain tilings. After the class has come to a conclusion about which polyominoes are rep-tiles, you may lead a discussion of why a given one, say the L, is not a rep-tile. The arguments start with forced moves: “I must place an L here this way, which forces me to place another one here, but now I see that if I place another L anywhere, the remaining space is not an L.”

Problem 5 is based on the same figure as Problem 5 of Lab 10.1 (Scaling on the Geoboard), except that here we are working outward, while there we were working inward.

If students have trouble with Problem 6b, suggest that they cut out three copies of the triangle and work with those. If even then no one can solve the puzzle, discuss Question C,

then draw the target triangle. Since the scaling factor is $\sqrt{3}$, use the hypotenuse as the short leg of the blown-up figure (because the hypotenuse is $\sqrt{3}$ times as long as the short leg in the original figure). The same sort of logic applies to Question D, which can be solved on grid or dot paper or on the geoboard.

Answers

1.

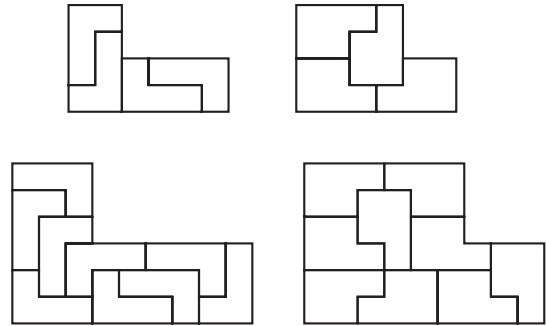

2. a. Four

b. Nine

3. Only the square and rectangular ones are rep-tiles.

4. Only the hexagon is not a rep-tile.

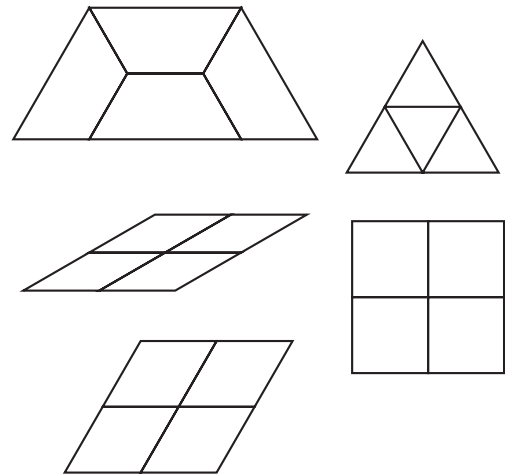

5. Surround it with three upside-down versions of itself.

6. a.

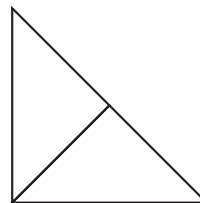

b.

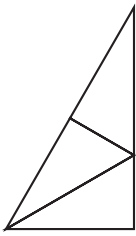

7. Only the parallelograms (including rhombi, rectangles, and squares) are rep-tiles.

Discussion Answers

- A. The area is multiplied by k^2 . See Lab 10.3 (Polyomino Blowups).
 B. The method in Problem 5 will work for any triangle, not just the ones on the template.
 C. The scaling factors are $\sqrt{2}$ and $\sqrt{3}$.
 D. The scaling factor must be $\sqrt{5}$. This suggests that the 1, 2, $\sqrt{5}$ right triangle may work. Indeed, it does.

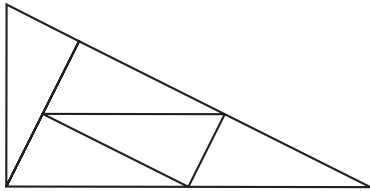

Lab 10.5: 3-D Blowups

Prerequisites: Students should know the definition of similar figures; Lab 10.3 (Polyomino Blowups) previews some of the ideas in this lesson in two dimensions.

Timing: Building 3-D blowups with the cubes can be quite time-consuming, especially if the original figure is large. Make sure students use a small number of blocks in the initial figure, no more than, say, four.

For Problems 2 and 3, many students find it very difficult to scale figures correctly in three dimensions. You will need to provide a lot of individual support, perhaps enlisting the help of talented students who finish their work quickly. The usual problem is a failure to conscientiously multiply *every* dimension by the

scaling factor. This is not necessarily an issue of understanding—concentration and perceptual acuity are also involved.

Students are likely to solve Question C by studying the tables of values. Here is an algebraic approach:

$$\begin{aligned} V &= k^3 V_0 \\ &= k^2 k V_0 \\ &= \frac{A}{A_0} k V_0 \\ &= \frac{V_0}{A_0} k A \end{aligned}$$

So the constant c mentioned in Discussion Answer C is the ratio of the initial volume to the initial surface area.

Answers

- The first and the last solids are similar.
 - 2
 - 14 and 56
 - 4
 - 3 and 24
 - 8
- Answers will vary.
- Answers will vary.
- Solutions for the surface area and volume columns will depend on the solid chosen.

Scaling factor	Surface area	Area ratio	Volume	Volume ratio
1		1		1
2		4		8
3		9		27
4		16		64
5		25		125
6		36		216

Discussion Answers

- A.** Each individual cube is scaled. Each of its faces goes from an area of 1 to an area of k^2 , since it is multiplied by k twice only (the multiplication in the direction that is perpendicular to that face does not affect its area). It follows that the ratio of surface areas is k^2 . Similarly, the volume of each individual cube gets multiplied by k^3 , since it is multiplied by k three times. It follows that the overall ratio of volumes must be k^3 .
- B.** $A = k^2 A_0$ and $V = k^3 V_0$
- C.** The formulas will be different for each original solid but will all be in the form $V = ckA$, where c is a constant determined by the shape and size of the original solid.

Lab 10.6: Tangram Similarity

Prerequisites: This lab includes some review of many ideas, including perimeter and area of similar figures and operations with radicals. The Pythagorean theorem, or at least its application to the particular case of an isosceles right triangle, is also relevant.

Students may find Problems 1 and 2 more challenging and time-consuming than you expect.

Another way to organize this lab is to start with Problems 5 and 6, which will motivate the methodical analysis in Problems 1–4.

It is the operations with radicals that makes this lab quite difficult for many students. Allow the use of calculators, but ask students to use simple radical form for their answers. That notation facilitates communication and reveals relationships that are obscured by the decimal approximations. Note, however, that familiarity with these approximations can be very useful to students who later study trigonometry and calculus, which is why you should not discourage calculator use.

It is easiest to answer Question D by thinking of the small triangles as having area 1. Then the total area of all tangram pieces is 16, which can be broken up as $15 + 1$, $14 + 2$, $13 + 3$, $12 + 4$, $11 + 5$, $10 + 6$, $9 + 7$, and $8 + 8$. This would yield ratios of area of 15 , 7 , $13/3$, 3 , $11/5$, $5/3$, $9/7$, and 1 . The scaling factors would have to be the square roots of these numbers. Only in the last case can the scaling factor actually exist for tangram figures.

Answers

- See Table 1.
- See Table 2.

Table 1

Legs			Perimeters				
Sm Δ	Md Δ	Lg Δ	Sm Δ	Md Δ	Lg Δ	Square	Parallelogram
1	$\sqrt{2}$	2	$2 + \sqrt{2}$	$2 + 2\sqrt{2}$	$4 + 2\sqrt{2}$	4	$2 + 2\sqrt{2}$
$\frac{\sqrt{2}}{2}$	1	$\sqrt{2}$	$1 + \sqrt{2}$	$2 + \sqrt{2}$	$2 + 2\sqrt{2}$	$2\sqrt{2}$	$2 + \sqrt{2}$
$\frac{1}{2}$	$\frac{\sqrt{2}}{2}$	1	$1 + \frac{\sqrt{2}}{2}$	$1 + \sqrt{2}$	$2 + \sqrt{2}$	2	$1 + \sqrt{2}$

Table 2

Legs			Areas				
Sm Δ	Md Δ	Lg Δ	Sm Δ	Md Δ	Lg Δ	Square	Parallelogram
1	$\sqrt{2}$	2	$\frac{1}{2}$	1	2	1	1
$\frac{\sqrt{2}}{2}$	1	$\sqrt{2}$	$\frac{1}{4}$	$\frac{1}{2}$	1	$\frac{1}{2}$	$\frac{1}{2}$
$\frac{1}{2}$	$\frac{\sqrt{2}}{2}$	1	$\frac{1}{8}$	$\frac{1}{4}$	$\frac{1}{2}$	$\frac{1}{4}$	$\frac{1}{4}$

3. The scaling factors are as follows.
 Small to medium, medium to large: $\sqrt{2}$
 Small to large: 2
 Large to medium, medium to small:

$$\frac{1}{\sqrt{2}} = \frac{\sqrt{2}}{2}$$

Large to small: $\frac{1}{2}$

4. The ratios of areas are as follows.
 Small to medium, medium to large: 2
 Small to large: 4
 Large to medium, medium to small: $\frac{1}{2}$
 Large to small: $\frac{1}{4}$

5. The answers are the same as for Problem 3.

6. Answers will vary.

Discussion Answers

A. The ratio of area is often easier to find, since it can often be done by seeing how many copies of the pieces making up the smaller figure can be used to cover the larger figure.

B. Answers will vary. Possibilities include the following:

- using the fact that the parallelogram and the square have the same area as the medium triangle
- multiplying an entire row by the scaling factor or the ratio of areas to get the other rows

C. 1

D. It is possible only if the scaling factor is 1.

Lab 10.7: Famous Right Triangles

This lesson pulls together much that has been learned in this and previous sections and also previews the type of thinking that underlies the next section on trigonometry.

It is difficult to overestimate the importance of these triangles. Just as students should be familiar with the multiplication tables, the perfect squares up to 15^2 , the value of π up to four places, and so on, they should know these triangles by heart

and be ready to use them when they come up. This is both a school survival strategy, as these numbers tend to appear often in texts and tests, and a concrete anchor to the all-important Pythagorean theorem. In the end, it is a matter of mathematical literacy.

Beware, however, of memorization that is not based on understanding! A colleague of mine told me that he asks his students this question: “A 30° , 60° , 90° triangle is a 3, 4, 5 triangle: always, sometimes, or never?” This is a great question that can reveal a serious lack of understanding. Try it with your students. I use this question in tests and quizzes every year.

Much of the work we have done in this book aims to lay a foundation of understanding to support these important results. The next section will lead students to a point where they will be able to find the angles in the 3, 4, 5 triangle without waiting for a future trigonometry course—and they will see that the angles are not 30° , 60° , and 90° .

Students will find that it is easier and less risky to solve Problems 7–12 by memorizing the sides of the reference triangles and scaling them than to solve them by using the Pythagorean theorem.

Answers

1.

	Leg ₁	Leg ₂	Hypotenuse
a.	1	1	$\sqrt{2}$
b.	1	2	$\sqrt{5}$
c.	1	$\sqrt{3}$	2
d.	3	4	5
e.	5	12	13

2. Triangle a: 1, 1, $\sqrt{2}$

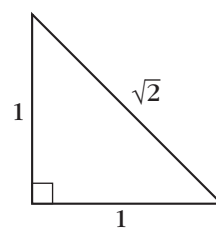

3. Triangle c: 1, $\sqrt{3}$, 2

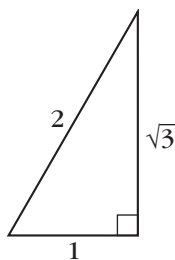

4. Triangles d and e

5.

	Leg ₁	Leg ₂	Hypotenuse
a.	2	2	$2\sqrt{2}$
b.	2	4	$2\sqrt{5}$
c.	2	$2\sqrt{3}$	4
d.	6	8	10
e.	10	24	26

6.

	Leg ₁	Leg ₂	Hypotenuse
a.	x	x	$x\sqrt{2}$
b.	x	$2x$	$x\sqrt{5}$
c.	x	$x\sqrt{3}$	$2x$
d.	$3x$	$4x$	$5x$
e.	$5x$	$12x$	$13x$

7. For triangle b: $10\sqrt{5}$; for triangle c: $10\sqrt{3}$

8. $60\sqrt{2}$

9. $\frac{30}{\sqrt{2}} = 15\sqrt{2}$

10. $35\sqrt{3}$

11. $\frac{80}{\sqrt{3}} = \frac{80\sqrt{3}}{3}$

12. 50 and $50\sqrt{2}$, or $25\sqrt{2}$ and $25\sqrt{2}$

Discussion Answers

A. Pattern blocks: the half-equilateral triangle (an understanding of which is necessary in order to find the area of most pattern blocks)

Tangrams: the isosceles right triangle

Geoboard: the 1, 2, $\sqrt{5}$ triangle;
the 3, 4, 5 triangle

11 Angles and Ratios

Lab 11.1: Angles and Slopes

Prerequisites: Students must understand the concept of slope. Lab 10.1 (Scaling on the Geoboard) and Lab 10.2 (Similar Rectangles) are highly recommended.

To fill out the table, students may use rubber bands on the circle geoboard, as shown in the figures. Division should yield the slope, and the built-in protractor provides the angle. You should probably demonstrate the correct procedure on the overhead. When a rubber band simply connects two pegs, you can get an accurate reading off the protractor or ruler by looking at the tick mark that lies between the two sides of the rubber band. In other cases, such as when you form a rectangle or triangle with a rubber band, you will need to think about which side of the rubber band to look at for an accurate reading. If you choose correctly, you should get a reading accurate to the nearest degree or millimeter.

In Problem 4, students find angles when given slopes. Although students are directed to make slope triangles in the first and fourth quadrants and to give angles between -90° and 90° , some students are bound to make slope triangles in the second quadrant. In that case, they might (incorrectly) give angles measured from the negative x -axis, or they might (correctly) give angles between 90° and 180° that correspond to the given slopes. This is a good opportunity to point out that the angle corresponding to a given slope is not unique. In Problem 5, students find slopes when given angles. The slope corresponding to a given angle *is* unique. You can discuss how and why these situations are different as you discuss Question A.

Some students may ask if there is a way to find the angle or the slope with a calculator. If so, tell them that there is such a way, but that it is not the subject of that day's lab. In fact, the slope for a given angle is obtained with the "tan" key, and

the angle between -90° and 90° for a given slope is found with the “ \tan^{-1} ” or “arctan” key. See the Trigonometry Reference Sheet and the section introduction for more on this.

If students are interested in getting more accuracy with the same apparatus, they can interpolate and extrapolate by using a string on the geoboard or a ruler on the paper copy of it (see page 245).

Answers

1–3. See student work.

4.

m	θ
0	0°
0.2	11°
0.4	22°
0.6	31°
0.8	39°
1	45°
1.25	51°
1.67	59°
2.5	68°
5	79°
None	90°
-5	-79°
-2.5	-68°
-1.67	-59°

5.

θ	m
0°	0.00
15°	0.27
30°	0.57
45°	1.00
60°	1.73
75°	3.73
90°	None
105°	-3.73
120°	-1.73
135°	-1.00
150°	-0.57
165°	-0.27
180°	0.00

Discussion Answers

A. Answers will vary.

The slopes of complementary angles are reciprocals of each other.

Slopes are positive for angles between 0° and 90° and between 180° and 270° .

The slope is 0 for 0° and 180° .

Slopes are negative for angles between 90° and 180° and between -90° and 0° .

Slopes are between 0 and 1 for angles between 0° and 45° and between 180° and 225° .

Slopes are greater than 1 for angles between 45° and 90° and between 225° and 270° .

B. The run is zero, and one cannot divide by zero.

C. Answers will vary. The first type of slope triangles work well for finding angles given slopes between 0 and 1 in the first table. The run stays a constant 10 cm (or 5 peg intervals), making it easy to identify the given slopes. It's necessary to use the second type of slope triangle to find angles given slopes whose absolute value is greater than 1. The third

type of slope triangle will work for finding slopes given any angle in the second table.

The fourth type is handy for finding slopes for given angles between 0° and 45° and between 135° and 180° . For those angles, once you read the rise off a vertical axis, finding the slope involves simply dividing by a run of 10.

- D.** The half-equilateral triangle is involved with both the 30° and 60° angles. The slopes obtained are consistent with the results of Lab 10.7, since $\sqrt{3}/1$ is close to 1.73 and $1/\sqrt{3}$ is close to 0.58.

The right isosceles triangle is involved with the 45° angle. The slope obtained is consistent with the results of Lab 10.7, since $1/1 = 1$.

Lab 11.2: Using Slope Angles

Prerequisites: Lab 11.1 (Angles and Slopes) is assumed.

This lab provides applications for the work in the previous lab. The discussion questions raise the issue of interpolating and extrapolating, since the tables we made in Lab 11.1 (Angles and Slopes) were clearly insufficient to deal with the full range of real-world problems of this type.

In doing this work, it is helpful to orient the figures so that the rise is vertical, the run is horizontal, and you are dealing only with positive slopes. Eventually, when the tangent ratio is officially introduced, the formulation “opposite over adjacent” will be more flexible, as it can be applied to a right triangle in any position.

After doing this lab, you can pursue any or all of the following three options if you want to do more work on this topic.

- Students can make a full table for slope angles, with 5° intervals. This is not as daunting as it seems; teamwork and patterns can help speed up the process. A method for doing it is described in Question A.

- You can use applications of the tangent ratio from any trig book. To solve the problems, students can use their circle geoboard or the circle geoboard sheet with a ruler to find the required ratios and angles, as suggested in the discussion.
- You can reveal that the slope ratio for a given angle is called the *tangent* of the angle and can be found on any scientific or graphing calculator, abbreviated as \tan . The angle corresponding to a given slope is called the *arctangent* and is abbreviated as \arctan or \tan^{-1} . A calculator set in degree mode will typically give an angle between -90° and 90° .

Answers

1. About 33 ft
2. About 30 m
3. **a.** See Problem 2.
b. About 112 m
4. About 39°
5. About 31°
6. **a.** About 12.3 ft
b. About 9.8 in.
7. About 233 m
8. About 67 units
9. See Problem 8.

Discussion Answers

- A.** Make a slope triangle. For example, in the case of the figure, a 35° angle yields a slope of $7/10$. Conversely, a slope of $7/10$ yields an angle of 35° .
- B.** 84° , 88° , 89° . As the slope increases, the angle gets closer to 90° .

Lab 11.3: Solving Right Triangles

Prerequisites: Lab 11.1 (Angles and Slopes) and Lab 11.2 (Using Slope Angles)

This lab raises a central problem of this whole section: solving right triangles. The work already done in the first two labs allows us to do just

that, as it is possible to solve any right triangle by using only the tangent ratio and the Pythagorean theorem given one side and one other part (side or acute angle). However, Problem 7 shows that this is extraordinarily difficult in the case where no leg is known. This discovery motivates Lab 11.4, where we learn about the two ratios that involve the hypotenuse, thereby making Problem 7 completely accessible.

Note that the answers given are based on using only two significant digits, because of the limitations of using the circle geoboard to find tans and arctans. If you have already introduced these terms, much greater accuracy is possible with the help of calculators.

Answers

1. You can find the other acute angle (69°).
2. None
3. All other parts (hypotenuse: $\sqrt{41}$; angles: about 39° and 51°)
4. All other parts (other leg: $\sqrt{13}$, or about 3.6; angles: first find the slope ratio, $3.6/6 = 0.6$, so the angles are about 31° and 59°)
5. All other parts (The other angle is 81° . The slope corresponding to the 9° angle is about 0.16, so the other leg is about 1.3 and the hypotenuse is about 8.1.)
6. All other parts (The other angle is 58° . The slope corresponding to that is about 1.6, so the other leg is about 16 and the hypotenuse is about 19.)
7. All other parts (The other angle is 25° . The slope for 65° is about 2.1. If the leg next to the 65° angle were 1, then the opposite leg would be 2.1 and the hypotenuse would be about 2.3. To find the actual legs, scale their assumed values by a factor of $4/2.3$, which results in lengths of about 1.7 and 3.7.)

Discussion Answers

- A. Two of the parts, including at least one side
- B. If you know where the angles are, you know that the long leg is opposite the larger angle.

If you only know the hypotenuse, you need to calculate the other leg. The legs would be equal if one angle is known to be 45° or if the leg and hypotenuse are in the ratio of 1 to $\sqrt{2}$.

- C. The way we make a transition from angles to sides is with the help of the slope ratio, which involves the legs but not the hypotenuse. In Problem 7, we had no legs, just the hypotenuse.

Lab 11.4: Ratios Involving the Hypotenuse

Prerequisites: Lab 11.1 and Lab 11.2

This lab parallels Lab 11.1, but it is about the sine and cosine. Note, however, that we limit ourselves to angles between 0° and 90° . We will work with angles outside of that range in the discussion of Lab 11.6 (The Unit Circle).

Answers

θ	opp/hyp	adj/hyp
0°	0	1
15°	0.26	0.97
30°	0.50	0.87
45°	0.71	0.71
60°	0.87	0.50
75°	0.97	0.26
90°	1	0

opp/hyp	θ
0	0°
0.2	12°
0.4	24°
0.6	37°
0.8	53°
1	90°

adj/hyp	θ
0	90°
0.2	78°
0.4	66°
0.6	53°
0.8	37°
1	0°

Discussion Answers

- A.** Answers will vary. The opp/hyp and adj/hyp ratios are switched for complementary angles. When the angle is 0° or 90° , we no longer have a triangle, but we still have a ratio. At 0° , the opposite side is 0 and the adjacent side coincides with the hypotenuse, so the opp/hyp ratio is 0 and the adj/hyp ratio is 1. At 90° , this is reversed.
- B.** Right isosceles triangle: correct, since $1/\sqrt{2}$ is about 0.71
- Half-equilateral triangle: correct, since $1/2 = 0.5$ and $\sqrt{3}/2$ is about 0.87
- A less visible famous triangle here is the 3, 4, 5, which shows up with the ratios of 0.6 and 0.8. We now see that its angles are approximately 37° and 53° .
- C.** No. The hypotenuse is always longer than the legs, so the ratio cannot be greater than 1.

Lab 11.5: Using the Hypotenuse Ratios

This lab parallels Lab 11.2 (Using Slope Angles) but uses the sine and cosine ratios instead of the tangent ratio.

As mentioned before, most right triangle trigonometry problems cannot be solved with the tables we constructed. However, the methods discussed in Question A should make it possible to solve any problem of this type. For Question A, a piece of string or a ruler can be used to get horizontal or vertical lines between pegs, or you may prefer to use the paper version on page 245. The official introduction of trig terminology is on the Trigonometry Reference Sheet that follows this lab.

Answers

1. Height: about 1.3 cm. Area: about 4.6 cm^2 .
2. About 4.8 cm^2
3. About 3.1 ft
4. About 37° and 53°

5. The height is $14.4/8$, or 1.8 cm. Thus, $\text{opp/hyp} = 1.8/3 = 0.6$, so the angle is about 37° .
6. About 56 m

Discussion Answer

- A.** To find the opp/hyp ratio for 35° , draw a horizontal line at 35° , and observe that it meets the vertical axis at 5.7. It follows that the ratio is $5.7/10 = 0.57$.

For the adj/hyp ratio, use a vertical line.

To find the angle when the ratio is known, start with the line and see where it meets the protractor.

Lab 11.6: The Unit Circle

Prerequisites: Students need the previous labs in this section and the Trigonometry Reference Sheet.

This is an introduction to the basic trig identities. After discussing them geometrically in this lab, it becomes possible to use algebraic notation such as $\sin(90 - x) = \cos x$ with some understanding. A good sequel to this lab is to make posters about all the identities to decorate the classroom. You may threaten to take the posters down at test time to impress upon the students the importance of knowing the identities. However, point out that it is far easier to reconstruct the unit circle sketches that accompany Questions D–G than it is to memorize the corresponding formulas. On the other hand, the Pythagorean identity and $\tan = \sin/\cos$ should be memorized and automatic.

Answers

1. For the tangent, calculate opp/adj in the larger triangle, where $\text{adj} = 1$.
For the sine and cosine, calculate opp/hyp and adj/hyp in the smaller triangle, where $\text{hyp} = 1$.

2.

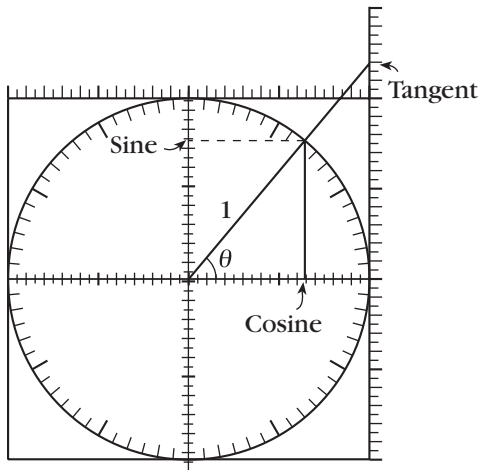

3.

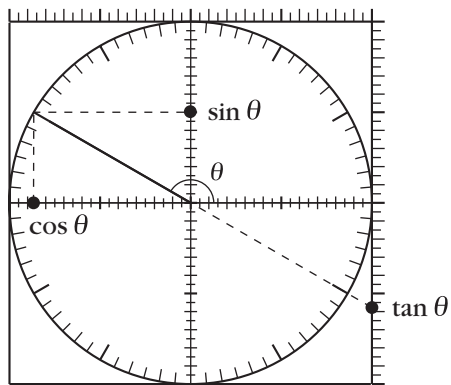

4. The sines of the two angles are equal. Their cosines and tangents are opposite in sign.

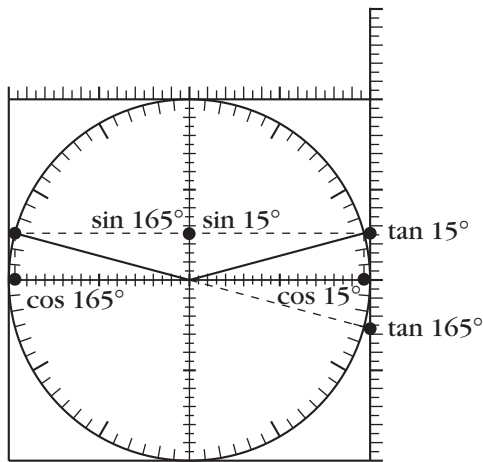

5. The cosines of the two angles are equal. Their sines and tangents are opposite in sign.

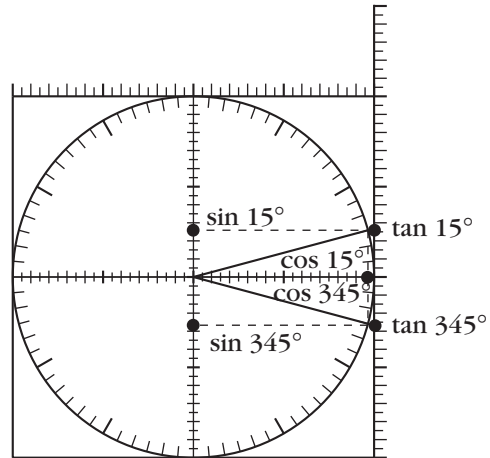

6. The tangents of the two angles are equal. Their sines and cosines are opposite in sign.

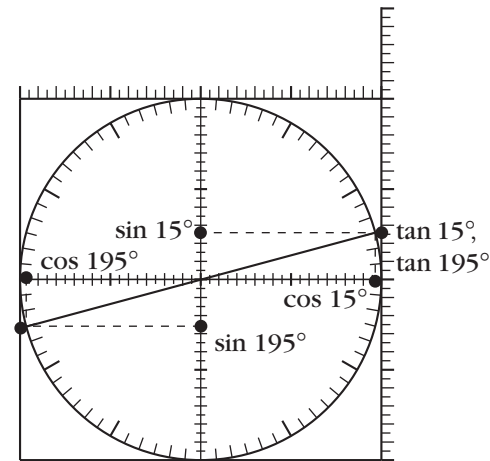

7. The tangents of the two angles are reciprocal. The sine of one is the cosine of the other.

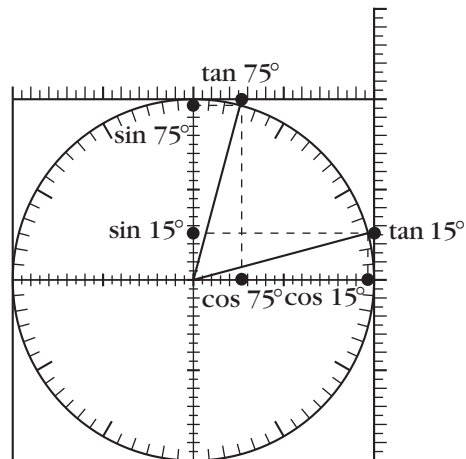

8. $\sin^2 \theta + \cos^2 \theta = 1$. It is the Pythagorean theorem in the smaller right triangle.

Discussion Answers

- A. The ratios are the same because the two triangles are similar. See Problem 1 regarding which triangle is more convenient in each case.
- B. $\tan = \frac{\text{opp}}{\text{adj}} = \frac{\sin}{\cos}$ in the small triangle
- C. In the slope triangle shown below, angle θ intersects the top axis at a point $(c, 1)$. $\tan \theta = \text{opp}/\text{adj} = 1/c$. Therefore, $c = 1/\tan \theta$.

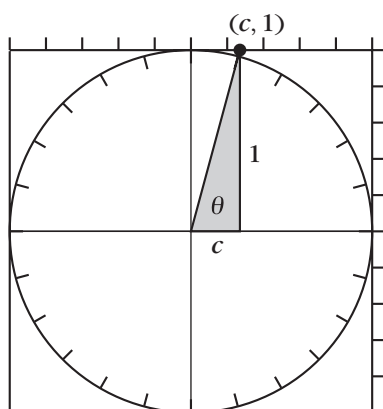

- D. See Problem 4.
- E. See Problem 7.
- F. See Problem 6.
- G. See Problem 5.
- H. See Question G.
- I. See Problem 7.

Lab 11.7: Perimeters and Areas on the CircleTrig Geoboard

Prerequisites: Right triangle trigonometry

Timing: Do not assign all of this in one sitting, as it could get tedious.

This lab applies basic trigonometry to various circle geoboard figures. It shows how much computing power is gained by having access to the trig ratios when measuring geometric

figures. Most of the problems in this lab would be impossible to solve without trigonometry.

Students can approach it in different ways, depending on which angles they use for their calculations, but all approaches boil down to some version of the strategy suggested in Question A. Problems 1a and 1b, in that sense, are basic to this lab. This is the end of a long journey with the geoboard: The Pythagorean theorem made it possible to find any measurements on the Cartesian 11×11 geoboard, and now trigonometry makes it possible to find any measurements on the circle geoboard.

Note that Problem 3 and Questions A and B are good preparations for the next and final lab, where we will get more insight into the surprising whole number in Problem 3e.

Answers

- a. $P = 38.48$; $A = 35.36$

b. $P = 39.32$; $A = 25$

c. $P = 51.67$; $A = 126.95$
- a. $P = 44.35$; $A = 96.59$

b. $P = 56.08$; $A = 193.18$

c. $P = 56.08$; $A = 193.18$ (If you divide the rectangle in 2b along the horizontal diagonal and flip the bottom half, you get the figure in 2c—the perimeter and area are unchanged.)
- a. $P = 51.96$; $A = 129.9$

b. $P = 56.57$; $A = 200$

c. $P = 60$; $A = 259.81$

d. $P = 61.23$; $A = 282.84$

e. $P = 62.12$; $A = 300$

f. $P = 62.65$; $A = 310.58$

Discussion Answers

- A. $P = 20 + 20\sin \theta$
 $A = 100(\sin \theta)(\cos \theta)$
- B. For the circle: $P = 62.83$ and $A = 314.16$, so the error in using the 24-gon figures is under 1 percent for the perimeter and under 2 percent for the area.

Lab 11.8: “ π ” for Regular Polygons

This final lab applies basic trigonometry to an interesting problem and makes a connection with a beautiful pattern block tessellation.

A historical note you can share with students:

The classical method of computing π is to find the perimeters of inscribed and circumscribed polygons. Archimedes, ca. 240 B.C., used 96-gons to find that π is between $223/71$ and $22/7$.

This gives π accurate to two decimal places.

The tessellation in Problem 3 (or at least its use to prove this result) was discovered by J. Kürschak in 1898 and brought to my attention by Don Chakerian one hundred years later. (See “Kürschak’s Tile” by G. L. Alexanderson and Kenneth Seydel, in *The Mathematical Gazette*, 62 (1978), p. 192.)

If your students notice the pattern mentioned in the answer to Question A, they may be curious about why the pattern holds. This can lead to a discussion of the identity for $\sin 2\theta$, which is the underlying reason for this pattern.

Answers

- $4r\sqrt{2}$
 - $2\sqrt{2}$, or about 2.82
 - $2r^2$
 - 2
- 3
- The pieces covering the dodecagon can be rearranged to cover three of the dotted-line bounded squares (move three triangles and six half-tan pieces). But those squares have area r^2 , so the area of the dodecagon is $3r^2$, and in this case $\pi_A = 3$.
- π_p is about 2.94; π_A is about 2.38.

5.

n	π_p	π_A
3	2.5981	1.299
4	2.8284	2
5	2.9389	2.3776
6	3	2.5981
8	3.0615	2.8284
9	3.0782	2.8925
10	3.0902	2.9389
12	3.1058	3
16	3.1214	3.0615
18	3.1257	3.0782
20	3.1287	3.0902
24	3.1326	3.1058

Discussion Answers

- A. Answers will vary.
- One interesting observation is that π_p for n is equal to π_A for $2n$.
- B. $\pi_p = n \sin(180^\circ/n)$ and
 $\pi_A = n \sin(180^\circ/n) \cos(180^\circ/n)$
- C. The π 's get closer to the actual value of π .
- D. Since each value of n yields two values for polygon- π , there are too many values for any one of them to be important. On the other hand, the only way to find the perimeter and area of a circle is with the actual value of π .

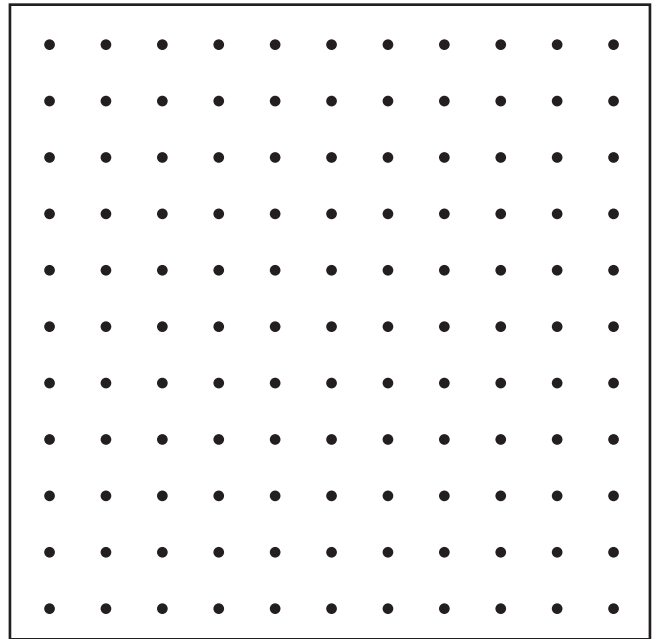
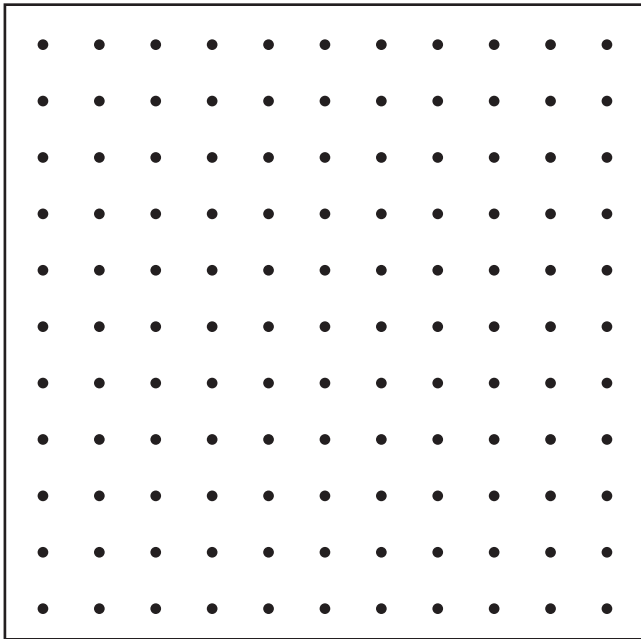
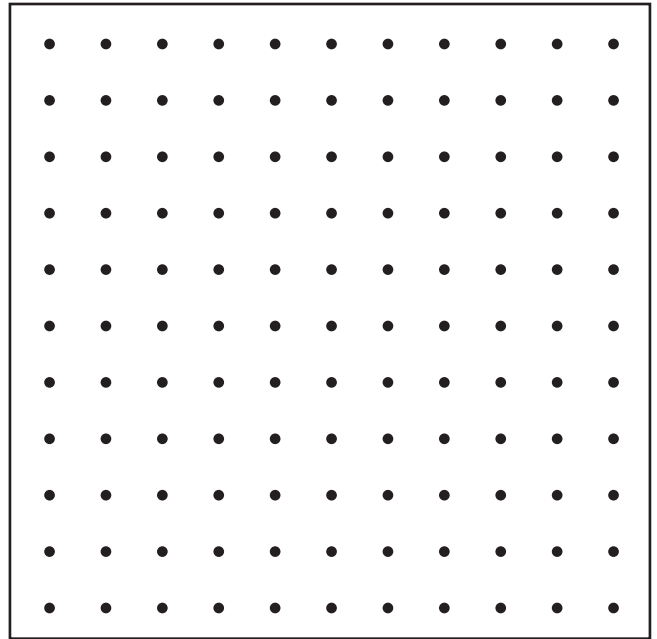
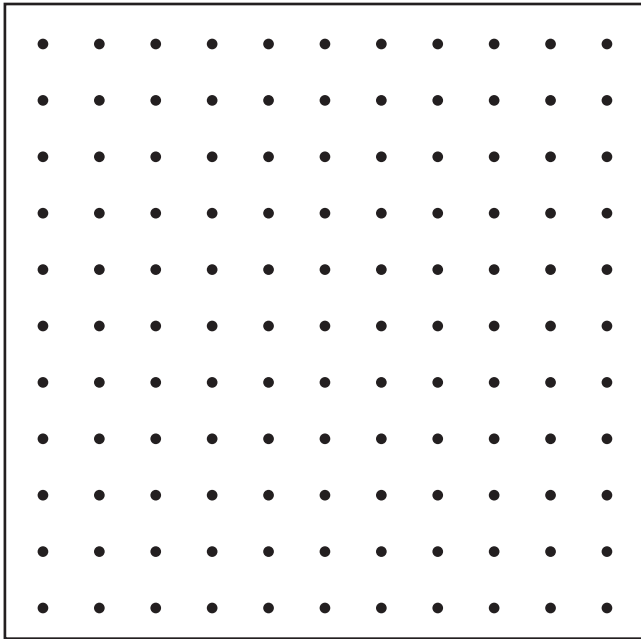

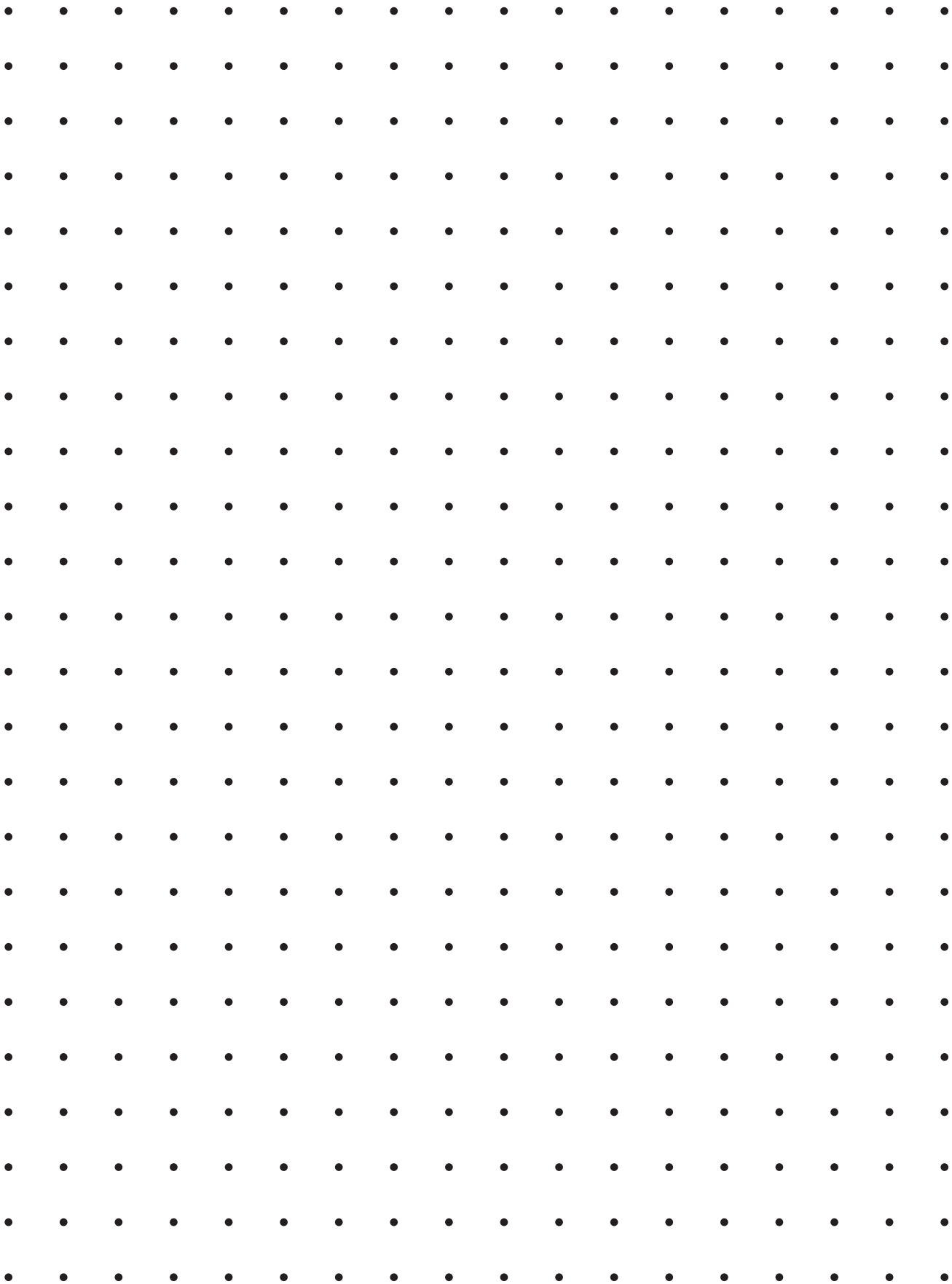

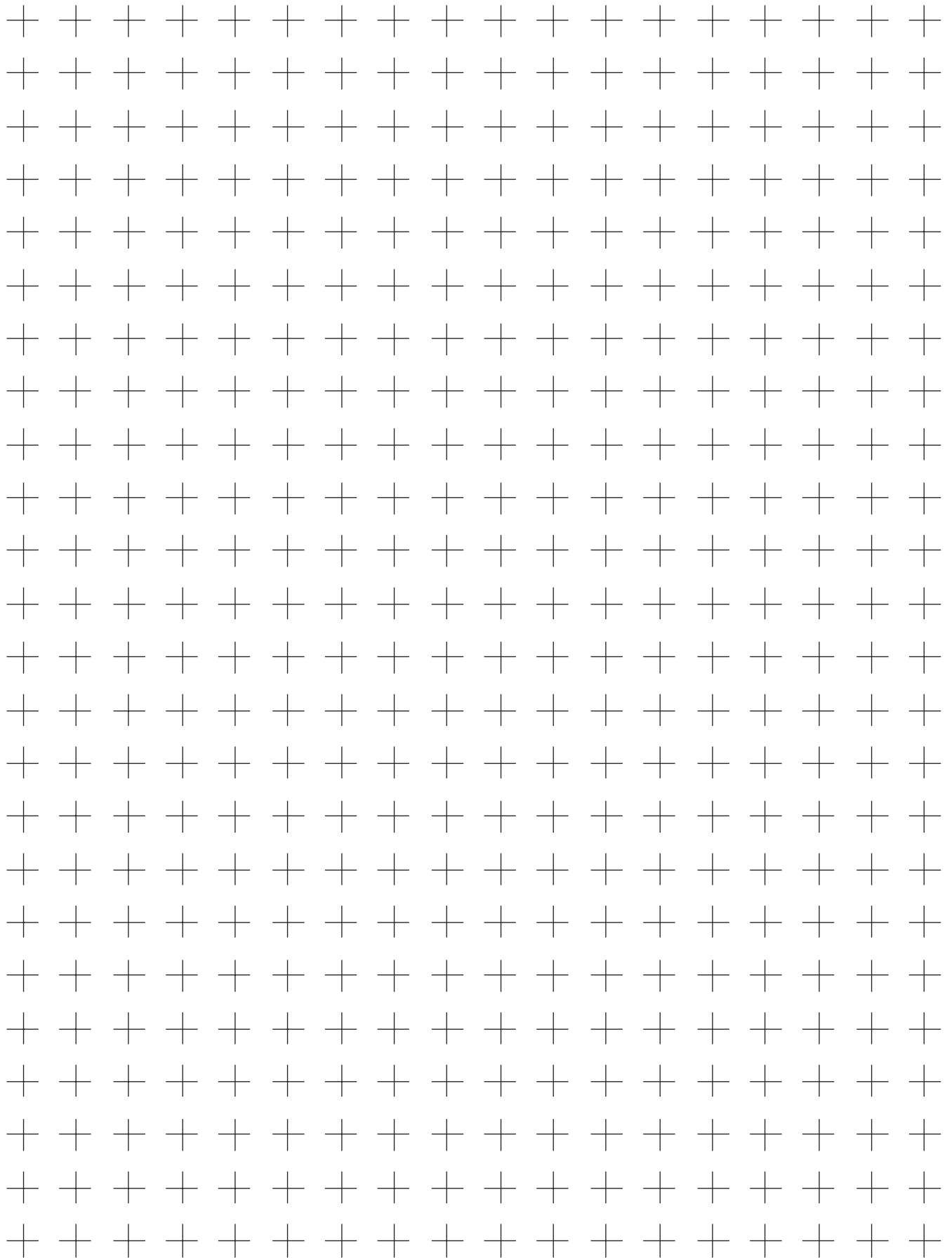

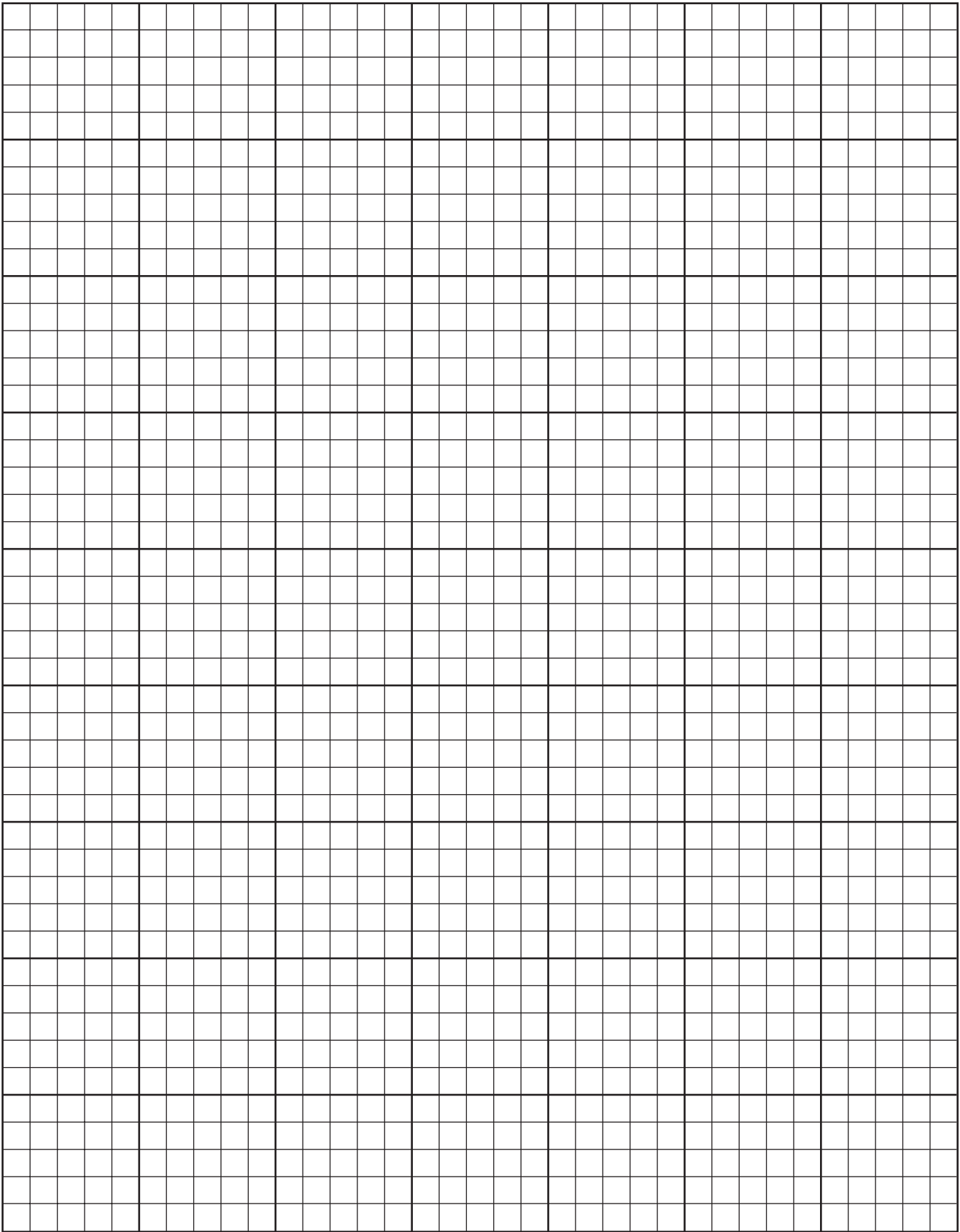

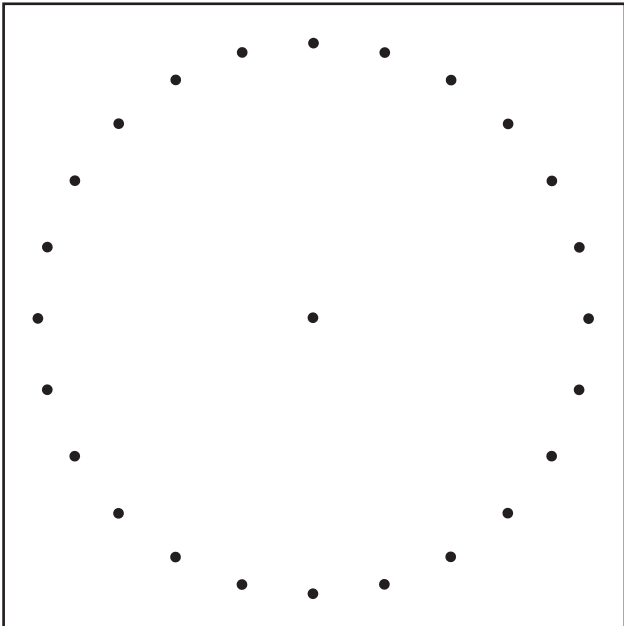
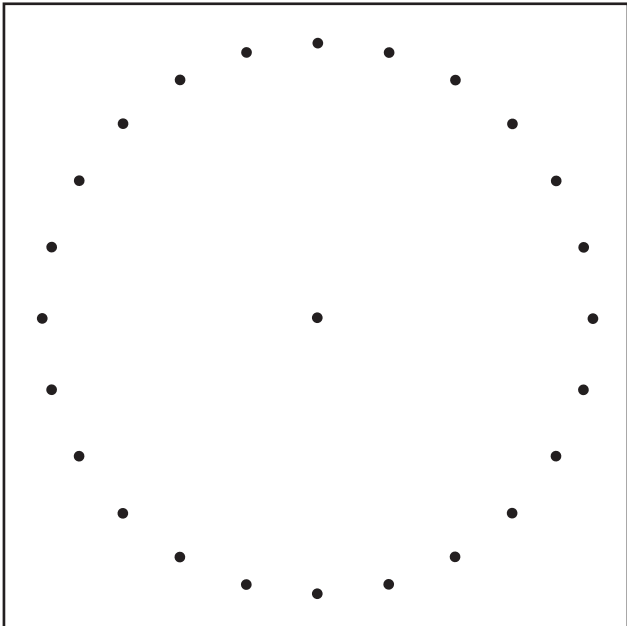
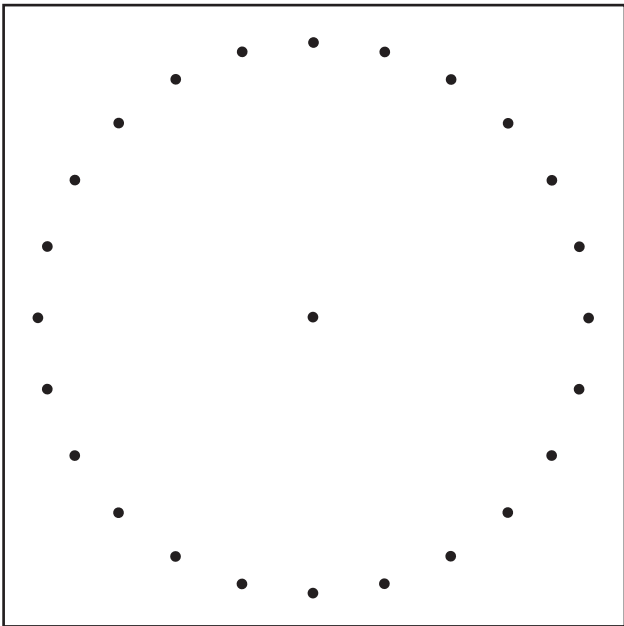
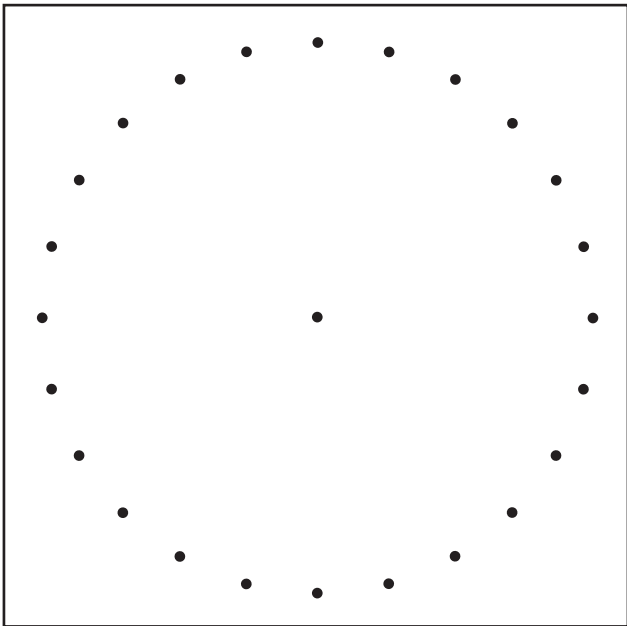

Instructions: Trace the figure onto a transparency. Cut along the solid lines (not the dashed lines). Tape the single square along an edge to form this shape:

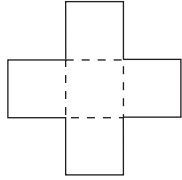

Fold to form an open cube.
Tape remaining edges.

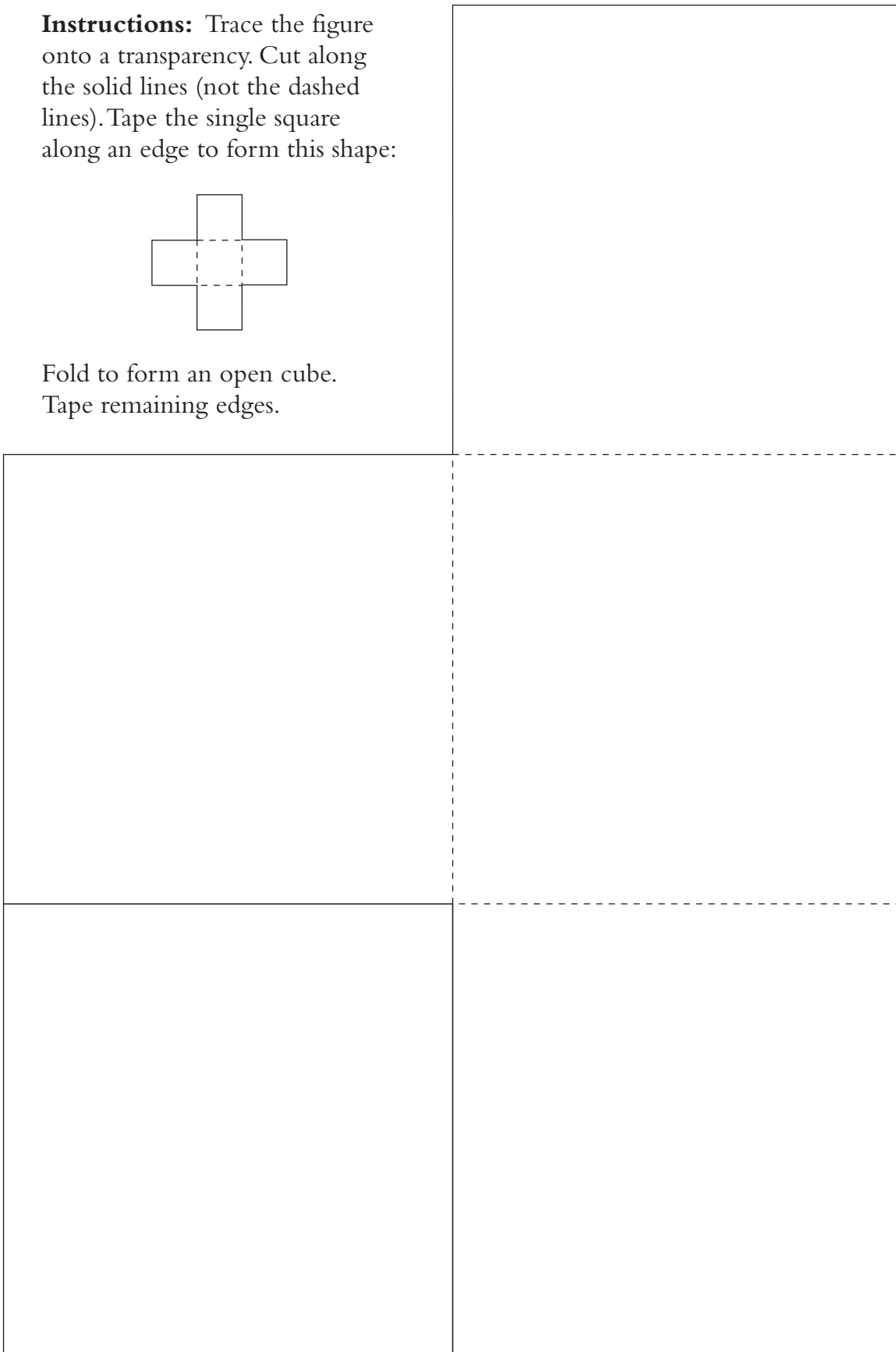

To make the radius of this circle exactly 10 cm, enlarge photocopies to 120%.

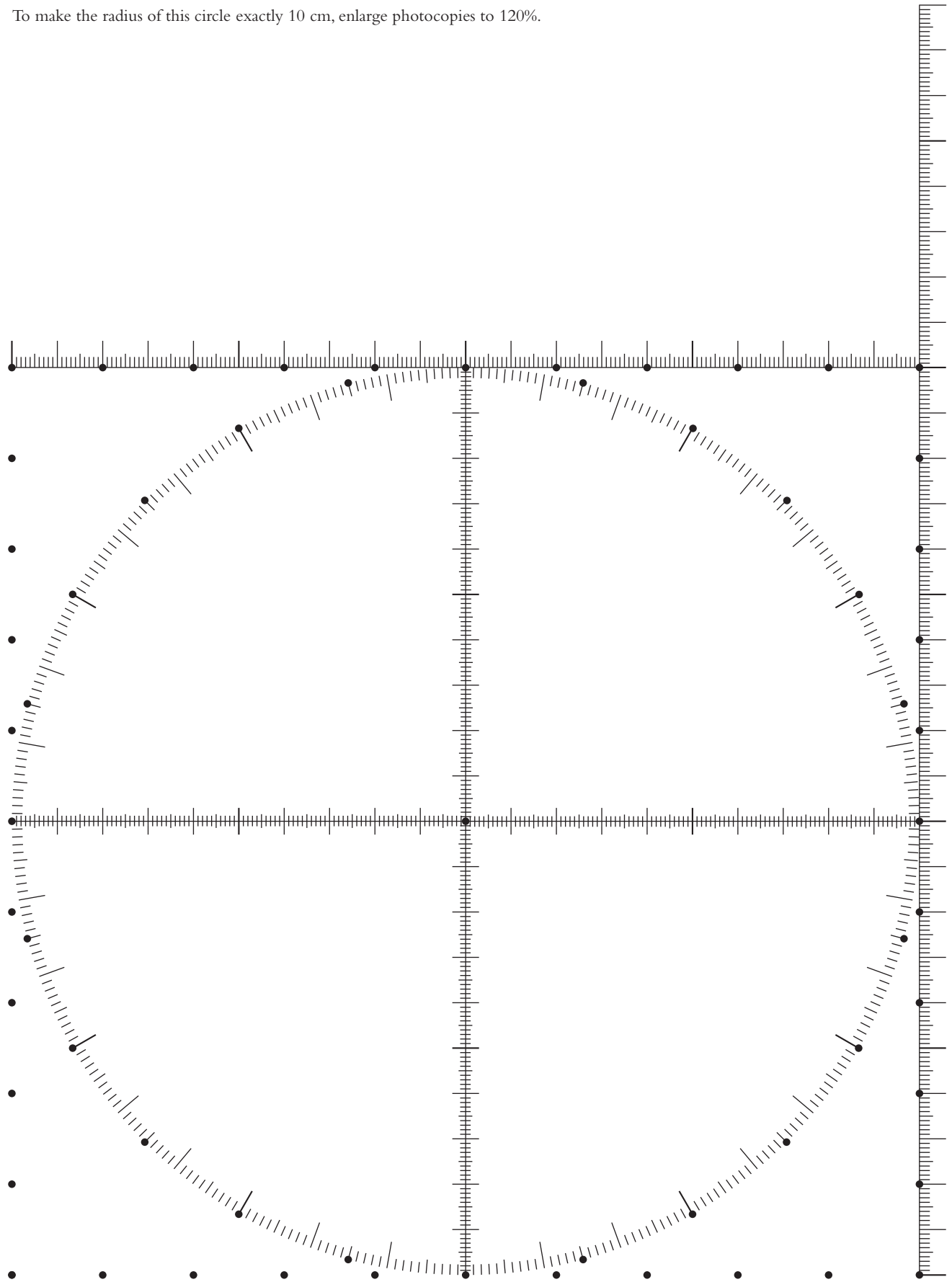

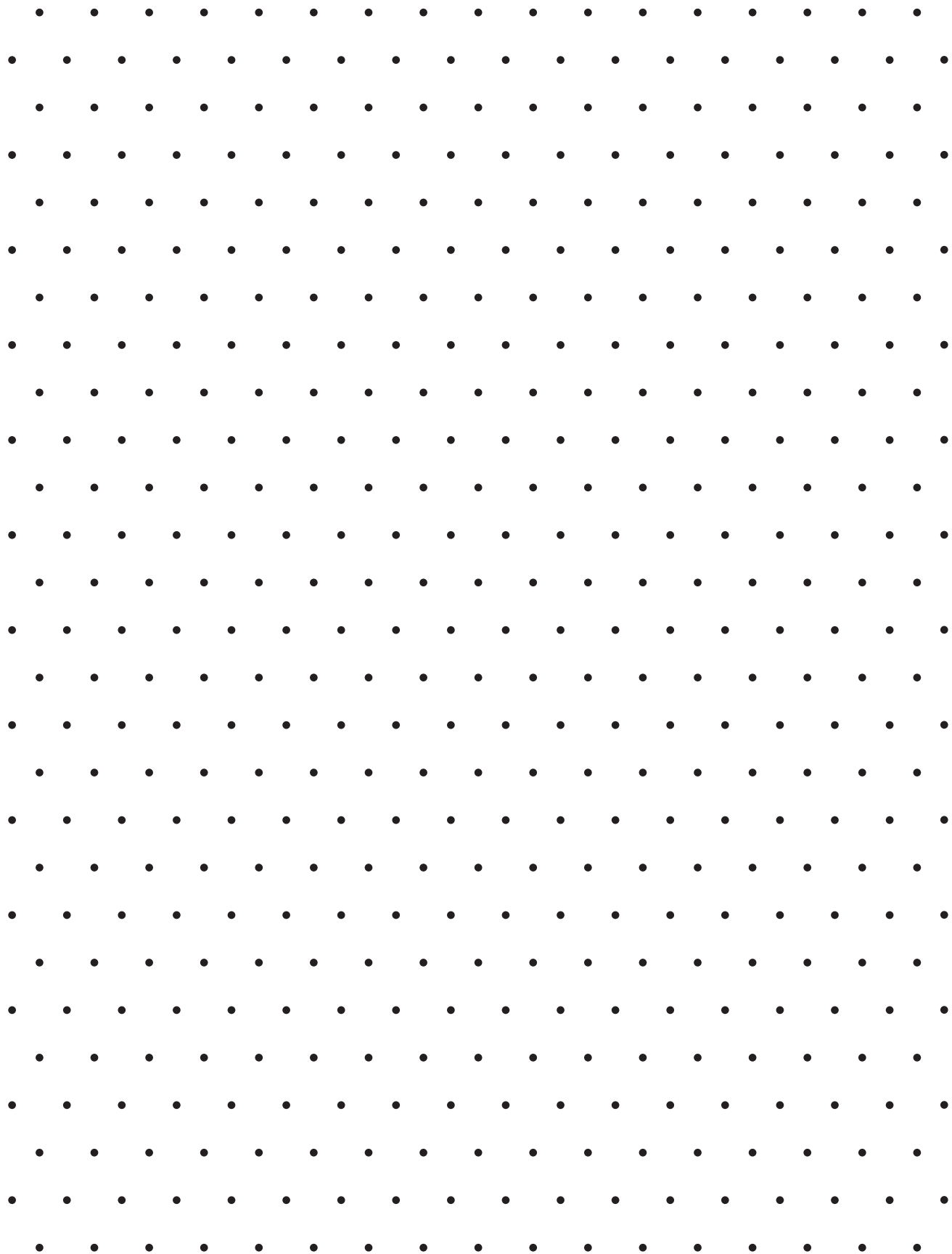

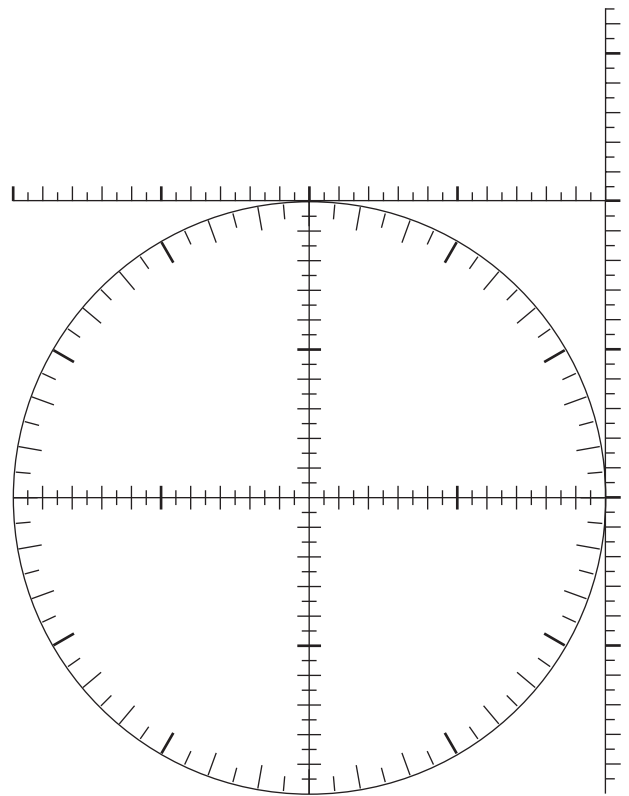
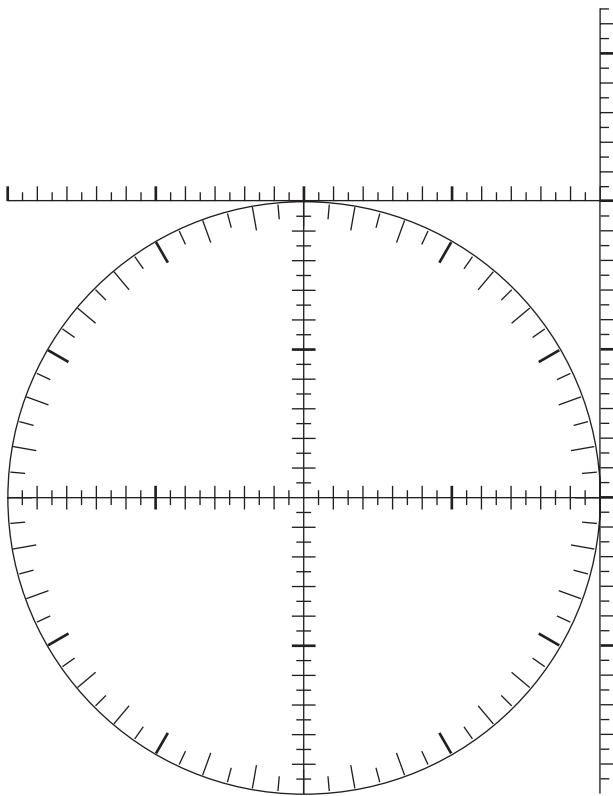
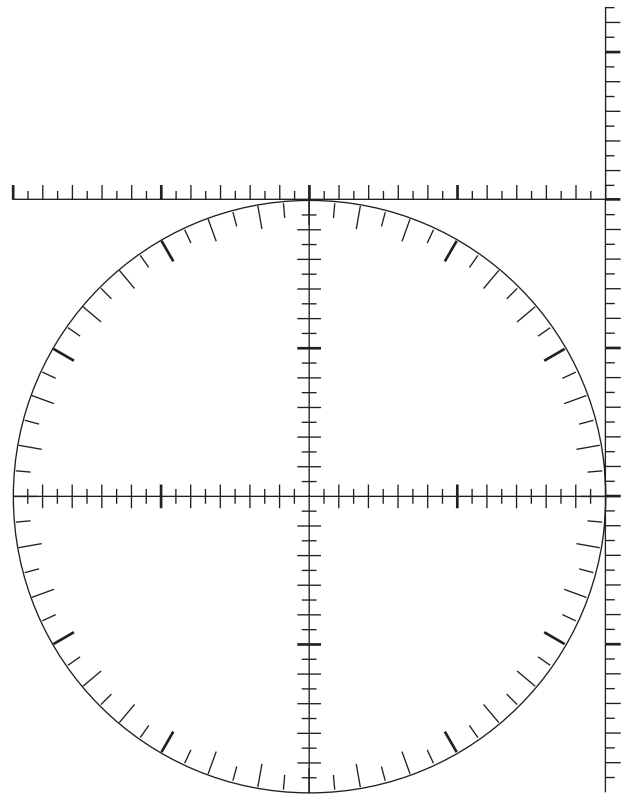
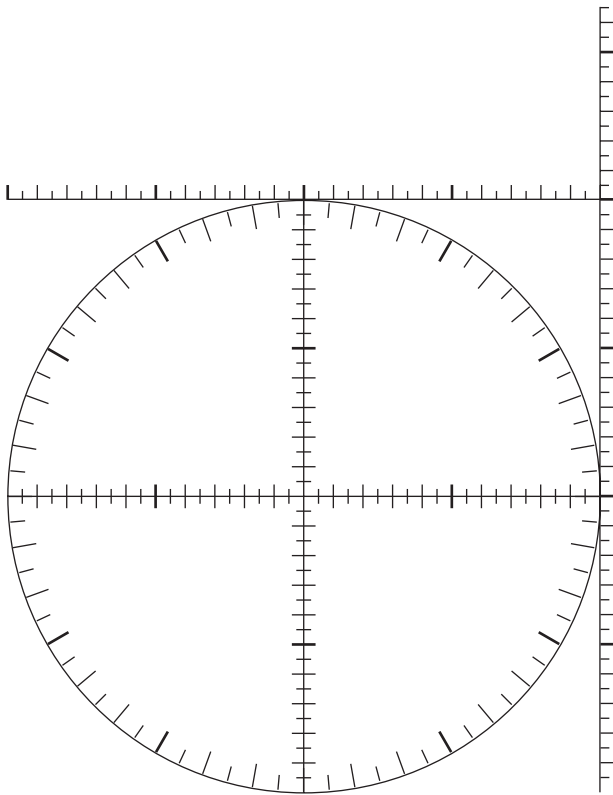

Bibliography

- Alexanderson, G.L. and K. Seydel. "Kürschak's Tile."
The Mathematical Gazette, vol. 62 (Oct. 1978) p. 192.
- Bennett, D. "A New Look at Circles." *Mathematics Teacher*,
vol. 82, no. 2 (Feb. 1989) pp. 90–93.
- DeTemple, D. W. and D. A. Walker "Some Colorful Mathematics."
Mathematics Teacher, vol. 89 (April 1996) p. 307ff.
- Dudeney, H. *Amusements in Mathematics*. New York: Dover Books, 1958.
- Gardner, M. *Mathematical Circus*. Chapters 5 and 15.
Washington D. C.: Mathematical Association of America, 1992.
- Gardner, M. "Mathematical Games." *Scientific American*, Recurring column.
- Gardner, M. *Mathematical Magic Show*, Chapter 13.
New York: Vintage Books, 1978.
- Gardner, M. *The New Ambidextrous Universe*.
New York: W. H. Freeman and Co., 1991.
- Gardner, M. *New Mathematical Diversions from Scientific American*. Chapter 13.
Washington D. C.: Mathematical Association of America, 1995.
- Gardner, M. *Scientific American Book of Mathematical Puzzles and Diversions*.
Chapter 13. Chicago: University of Chicago Press, 1987.
- Gardner, M. *Sixth Book of Mathematical Diversions Scientific American*.
Chapter 18. Chicago: University of Chicago Press, 1983.
- Gardner, M. *Time Travel and Other Mathematical Bewilderments*.
New York: W. H. Freeman and Co., 1987.
- Golomb, S. W. *Polyominoes: Puzzles, Patterns, Problems, and Packings*.
Princeton, N. J.: Princeton University Press, 1994.
- Grunbaum, B. and G. C. Shephard. *Tilings and Patterns*.
New York: W. H. Freeman and Co., 1987.
- Krause, E. F. *Taxicab Geometry*. New York: Dover, 1987.
- Picciotto, H. *Pentomino Activities, Lessons, and Puzzles*.
Chicago: Creative Publications, 1984.
- Picciotto, H. *SuperTangram Activities*. vol. I and II.
Chicago: Creative Publications, 1986.
- Serra, M. *Patty Paper Geometry*. Emeryville, Calif.: Key Curriculum Press.
- Stevens, P. S. *Handbook of Regular Patterns: An Introduction to Symmetry
in Two Dimensions*. Cambridge, Mass.: MIT Press, 1980.
- Wah, A. and H. Picciotto. *Algebra: Themes, Tools, Concepts*.
Chicago: Creative Publications, 1994.